

STATE OF NORTH CAROLINA
DEPARTMENT OF TRANSPORTATION
HIGHWAY DIVISION 8

**CONTRACT PROPOSAL
SMALL BUSINESS ENTRPRISE**

DATE AND TIME OF BID OPENING: APRIL 23, 2024 AT 2:00 PM

CONTRACT ID: 12123882

WBS ELEMENT NO.: 49218.16 & 49218.24

COUNTY: HOKE COUNTY

LOCATION: FORT LIBERTY

ROUTES: KING ROAD, MANCHESTER ROAD, MORGANTON ROAD, PLANK ROAD, AND MORRISON BRIDGE ROAD.

TYPE OF WORK: LONG ARM MOWING AND TREE REMOVAL.

NOTICE:

ALL BIDDERS SHALL COMPLY WITH ALL APPLICABLE LAWS REGULATING THE PRACTICE OF GENERAL CONTRACTING AS CONTAINED IN CHAPTER 87 OF THE GENERAL STATUTES OF NORTH CAROLINA WHICH REQUIRES THE BIDDER TO BE LICENSED BY THE N.C. LICENSING BOARD FOR CONTRACTORS WHEN BIDDING ON ANY NON-FEDERAL AID PROJECT WHERE THE BID IS \$30,000 OR MORE, EXCEPT FOR CERTAIN SPECIALTY WORK AS DETERMINED BY THE LICENSING BOARD. BIDDERS SHALL ALSO COMPLY WITH ALL OTHER APPLICABLE LAWS REGULATING THE PRACTICES OF ELECTRICAL, PLUMBING, HEATING AND AIR CONDITIONING AND REFRIGERATION CONTRACTING AS CONTAINED IN CHAPTER 87 OF THE GENERAL STATUTES OF NORTH CAROLINA. NOTWITHSTANDING THESE LIMITATIONS ON BIDDING, THE BIDDER WHO IS AWARDED ANY FEDERAL - AID FUNDED PROJECT SHALL COMPLY WITH CHAPTER 87 OF THE GENERAL STATUTES OF NORTH CAROLINA FOR LICENSING REQUIREMENTS WITHIN 60 CALENDAR DAYS OF BID OPENING.

THIS IS A ROADWAY PROJECT.

BID BONDS ARE NOT REQUIRED.

NAME OF BIDDER

ADDRESS OF BIDDER

PROPOSAL FOR THE CONSTRUCTION OF
CONTRACT No. 12123882 IN Hoke County, NORTH CAROLINA
DEPARTMENT OF TRANSPORTATION,
RALEIGH, NORTH CAROLINA

The Bidder has carefully examined the location of the proposed work to be known as Contract No. **12123882**; has carefully examined the plans and specifications, which are acknowledged to be part of the proposal, the special provisions, the proposal, the form of contract; and thoroughly understands the stipulations, requirements and provisions. The undersigned bidder agrees to be bound upon his execution of the bid and subsequent award to him by the Department of Transportation in accordance with this proposal. Payment and performance bonds are not required on this project. The undersigned Bidder further agrees to provide all necessary machinery, tools, labor, and other means of construction; and to do all the work and to furnish all materials, except as otherwise noted, necessary to perform and complete the said contract in accordance with the *2024 Standard Specifications for Roads and Structures* by the dates(s) specified in the Project Special Provisions and in accordance with the requirements of the Engineer, and at the unit or lump sum prices, as the case may be, for the various items given on the sheets contained herein.

The Bidder shall provide and furnish all the materials, machinery, implements, appliances and tools, and perform the work and required labor to construct and complete Contract No. **12123882** in **Hoke County**, for the unit or lump sum prices, as the case may be, bid by the Bidder in his bid and according to the proposal, plans, and specifications prepared by said Department, which proposal, plans, and specifications show the details covering this project, and hereby become a part of this contract.

The published volume entitled *North Carolina Department of Transportation, Raleigh, Standard Specifications for Roads and Structures, January 2024* with all amendments and supplements thereto, is by reference incorporated into and made a part of this contract; that, except as herein modified, all the construction and work included in this contract is to be done in accordance with the specifications contained in said volume, and amendments and supplements thereto, under the direction of the Engineer.

If the proposal is accepted and the award is made, the contract is valid only when signed either by the Contract Officer or such other person as may be designated by the Secretary to sign for the Department of Transportation. The conditions and provisions herein cannot be changed except over the signature of the said Contract Officer or Division Engineer.

The quantities shown in the itemized proposal for the project are considered to be approximate only and are given as the basis for comparison of bids. The Department of Transportation may increase or decrease the quantity of any item or portion of the work as may be deemed necessary or expedient.

An increase or decrease in the quantity of an item will not be regarded as sufficient ground for an increase or decrease in the unit prices, nor in the time allowed for the completion of the work, except as provided for the contract.

INSTRUCTIONS TO BIDDERS

**PLEASE READ ALL INSTRUCTIONS CAREFULLY
BEFORE PREPARING AND SUBMITTING YOUR BID.**

All bids shall be prepared and submitted in accordance with the following requirements. Failure to comply with any requirement may cause the bid to be considered irregular and may be grounds for rejection of the bid.

TRADITIONAL PAPER BIDS:

1. Download the entire proposal from the Connect NCDOT website and return the entire proposal with your bid.
2. In accordance with Article 102-3 of the *Standard Specifications*, registration on the Interested Parties List is required unless SP1 G02 Interested Parties List Not Required provision is included in the proposal.
3. All entries on the itemized proposal sheet (bid form) shall be written in ink or typed.
4. The Bidder shall submit a unit price for every item on the itemized proposal sheet. The unit prices for the various contract items shall be written in figures. Unit prices shall be rounded off by the Bidder to contain no more than FOUR decimal places.
5. An amount bid shall be entered on the itemized proposal sheet for every item. The amount bid for each item shall be determined by multiplying each unit bid by the quantity for that item, and shall be written in figures in the "Amount" column of the form.
6. The total amount bid shall be written in figures in the proper place on the bid form. The total amount bid shall be determined by adding the amounts bid for each item.
7. Changes to any entry shall be made by marking through the entry in ink and making the correct entry adjacent thereto in ink. A representative of the Bidder shall initial the change in ink. Do not use correction fluid, correction tape or similar product to make corrections.
8. The bid shall be properly executed on the included **Execution of Bid – Non-collusion, Debarment and Gift Ban Certification** form. All bids shall show the following information:
 - a. Name of corporation, partnership, Limited Liability Company, joint venture, individual or firm, submitting bid.
Corporations that have a corporate seal shall include it on the bid, otherwise write your corporations name in the seal location.
 - b. Name of individual or representative submitting bid and position or title held on behalf of the bidder.
 - c. Name, signature, and position or title of witness.
9. The bid shall not contain any unauthorized additions, deletions, or conditional bids.
10. The Bidder shall not add any provision reserving the right to accept or reject an award, or to enter into a contract pursuant to an award.
11. **THE PROPOSAL WITH THE ITEMIZED PROPOSAL SHEET ATTACHED SHALL BE PLACED IN A SEALED ENVELOPE AND SHALL BE DELIVERED TO AND RECEIVED IN THE NCDOT DIVISION OFFICE, LOCATED AT 121 DOT Drive, BY 2:00 PM ON, April 23, 2024.**
12. The sealed bid must display the following statement on the front of the sealed envelope:

QUOTATION FOR CONTRACT 12123882 – LONG ARM MOWING AND TREE CUTTING ON FORT LIBERTY IN HOKE COUNTY TO BE OPENED AT 2:00 PM, TUESDAY, APRIL 23, 2024.

As well as the following information:

- a. Name of corporation, partnership, Limited Liability Company, joint venture, individual or firm, submitting bid.
- b. Name of individual or representative submitting bid and position or title held on behalf of the bidder.
- c. Address of corporation, partnership, Limited Liability Company, joint venture, individual or firm, submitting bid.
- d. SAP Vendor Number of corporation, partnership, Limited Liability Company, joint venture, individual or firm, submitting bid.
- e. Contractor Number, if applicable, of corporation, partnership, Limited Liability Company, joint venture, individual or firm, submitting bid.

13. If delivered by mail, the sealed envelope shall be placed in another sealed envelope and the outer envelope shall be addressed as follows:

**N. C. DEPARTMENT OF TRANSPORTATION
DIVISION OF HIGHWAYS, DIVISION 8
ATTN: Chad Brown
121 DOT Drive
Carthage, NC 28327**

14. Questions should be emailed 7 calendar days prior to the bid opening to **Chad Brown** at **cgbrown1@ncdot.gov**. Contact with any other NCDOT personnel concerning this project is strictly prohibited, unless otherwise noted, and may result in bids being considered non-responsive.

PROJECT SPECIAL PROVISIONS

GENERAL

SCOPE OF WORK:

This contract is for tree cutting and long-arm mowing on designated roads in Fort Liberty, Hoke County, NC in Division 8. Work will consist of cutting designated trees and tree limbs, with removal of debris and/or chipping in accordance with Section 200-3 and 200-5 of the current *Standard Specifications*. Long-arm mowing with mulching/pickup along designated roads. All work shall be completed during daylight hours.

All work and materials shall be in accordance with the provisions of the General Guidelines of this contract, the Project Special Provisions, the current edition of the North Carolina Department of Transportation *Standard Specifications for Roads and Structures*, the current edition of the North Carolina Department of Transportation *Roadway Standards Drawings*, and the current edition of the *Manual of Uniform Traffic Control Devices* (MUTCD).

Wherever reference is given to codes, or standard specifications, or other data published by regulating agencies or accepted organizations, including but not limited to N.C. State Building Codes, Federal Specifications, ASTM Specifications, N.C. Department of Transportation 'Standard Specifications for Roads and Structures', and the like, it shall be understood that such reference is to the latest edition including addenda published prior to the date of the contract documents.

The Contractor shall keep himself fully informed of all Federal, State and local laws, ordinances, and regulations, and shall comply with the provisions of Section 107 of the *Standard Specifications*.

Traffic Control will be performed by the Contractor.

SMALL BUSINESS ENTERPRISE PROGRAM

This is a **Small Business Enterprise Program** project, and as such, will be restricted to businesses with a gross income of not more than \$1.5 million, excluding materials during the previous calendar year. **Only contractors currently certified as a SBE contractor by the Contractual Services Unit of NCDOT and listed in the Directory of Transportation Firms at bid opening will be eligible to bid on this project.**

Per G.S. 136-28.10, a North Carolina General Contractor's license may be waived for SBE contracts. For this project, the North Carolina General Contractor's license will be waived.

Per G.S. 136-28.10, contract payment and performance bonds may be waived. For this project, the contractor payment and performance bond will be waived.

Since general liability insurance is required, a copy of a certificate of insurance must also be submitted. Proof of small business status will be the previous year's income tax return. A copy of this return does not have to be submitted with this bid proposal, but may be requested at a later date.

Prospective bidders who qualify for the SBE program and are not currently certified should submit a completed application packet prior to bid submittal to allow time for review. The application packet and additional information on the program may be obtained online at:

<https://connect.ncdot.gov/business/SmallBusiness/Pages/SBE%20Certification%20Process.aspx>

SMALL BUSINESS ENTERPRISE:

(4-19-22)

SP1 G73

This contract let pursuant to the Small Business Enterprise provisions of N.C. General Statute §136-28.10. In accordance with N.C. General Statute §136-28.10, an award in a contract may be for an amount less but shall not exceed \$1,000,000 per year. No payments in excess of this amount will be disbursed, in accordance with the Statute.

SITE INVESTIGATION AND REPRESENTATION:

(3-3-2014)

102-6

SPD 01-280

By signing the proposal documents, the Contractor acknowledges that:

- (A) He understands the nature of the work and general and local conditions, particularly those bearing on transportation;
- (B) He is familiar with the availability and cost of labor and materials;
- (C) He will to adhere to State regulations for safety and security of property, roads, and facilities;
- (D) He is able to prosecute the work in accordance with all applicable local, state and federal rules and regulations, and;
- (E) He has thoroughly investigated the project site(s).

Any failure on the part of the Contractor to acquaint himself with all available information shall not relieve him from the responsibility any aspect of the contracting process. No adjustment in contract time or contract prices will be made due to the Contractor's negligence in familiarizing himself with the contract or project site(s).

MANDATORY PREBID MEETING:

A mandatory Pre-Bid Meeting will be held at 10:00 AM on Thursday, April 11, 2024, at the Carthage Division Office, 121 DOT Drive, Carthage, NC 28327. Attendance at this meeting is required in order to bid on the project.

GENERAL CONTRACTOR LICENSING

Per GS 136-28.14 a General Contractor Licensing is not required for this project.

BOND REQUIREMENTS – No Bonds Required

(06-01-16)

SPD 01-420B

The provisions of Articles 102-10 and 103-7 of the 2018 Standard Specifications for Roads and Structures are waived for this project. No bonds required.

INTERESTED PARTIES LIST NOT REQUIRED:

(6-21-22)(Rev. 2-20-24)

102

SP1 G02

Revise the *Standard Specifications* as follows:

The *Interested Parties List* sign up process is not applicable to this contract.

Page 1-13, Article 102-3 PROPOSALS AND INTERESTED PARTIES LIST, lines 12-15, delete the first paragraph.

Page 1-14, Article 102-8 PREPARATION AND SUBMISSION OF BIDS, lines 43-44, delete the first sentence of the first paragraph.

CONTRACT TIME AND LIQUIDATED DAMAGES:

(7-1-95) (Rev. 12-18-07)

108

SP1 G10 A

The date of availability for this contract is **May 13, 2024**.

The completion date for this contract is **August 01, 2024**.

The Engineer reserves the right to extend the completion date if additional construction needs remain at the end of the completion date.

Liquidated damages for this contract are Six Hundred Dollars (\$600.00) per calendar day.

INTERMEDIATE CONTRACT TIME NUMBER [#1] AND LIQUIDATED DAMAGES:

(2-20-07)

108

RG14 A

The Contractor shall not close or narrow a lane of traffic on **All Maps**, detain and/or alter the traffic flow on or during holidays, holiday weekends, special events, or any other time when traffic is unusually heavy, including the following schedules:

DAY AND TIME RESTRICTIONS
No Work Permitted on Sundays

HOLIDAY AND HOLIDAY WEEKEND LANE CLOSURE RESTRICTIONS

1. For **unexpected occurrence** that creates unusually high traffic volumes, as directed by the Engineer.
2. For **New Year's Day**, between the hours of **6:30 a.m.** December 31st and **8:00 p.m.** January 2nd. If New Year's Day is on a Friday, Saturday, Sunday or Monday, then until **8:00 p.m.** the following Tuesday.
3. For **Easter**, between the hours of **6:30 a.m.** Thursday and **8:00 p.m.** Monday.
4. For **Memorial Day**, between the hours of **6:30 a.m.** Friday and **8:00 p.m.** Tuesday.
5. For **Independence Day**, between the hours of **6:30 a.m.** the day before Independence Day and **8:00 p.m.** the day after Independence Day.

If **Independence Day** is on a Friday, Saturday, Sunday or Monday, then between the hours of **6:30 a.m.** the Thursday before Independence Day and **8:00 p.m.** the Tuesday after Independence Day.

6. For **Labor Day**, between the hours of **6:30 a.m.** Friday and **8:00 p.m.** Tuesday.
7. For **Thanksgiving Day**, between the hours of **6:30 a.m.** Tuesday and **8:00 p.m.** Monday.
8. For **Christmas**, between the hours of **6:30 a.m.** the Friday before the week of Christmas Day and **8:00 p.m.** the following Tuesday after the week of Christmas Day.
9. Holidays and holiday weekends shall include New Year's, Easter, Memorial Day, Independence Day, Labor Day, Thanksgiving, and Christmas. The Contractor shall schedule his work so that lane closures are not required during these periods, unless otherwise directed by the Engineer.

The time of availability for this intermediate contract work shall be the time the Contractor begins to install all traffic control devices for lane closures according to the time restrictions listed herein.

The completion time for this intermediate contract work shall be the time the Contractor is required to complete the removal of all traffic control devices for lane closures according to the time restrictions stated herein and restore traffic to a **2-lane, 2-way** traffic pattern.

The liquidated damages are **Six Hundred Dollars (\$ 600.00)** per hour.

NO MAJOR CONTRACT ITEMS:

(2-19-02) (Rev. 8-21-07)

104

SP1 G31

None of the items included in this contract will be major items.

SCHEDULE OF ESTIMATED COMPLETION PROGRESS:

(7-15-08) (Rev. 1-16-24)

108-2

SP1 G58

The Contractor's attention is directed to the Standard Special Provision entitled *Availability of Funds Termination of Contracts* included elsewhere in this proposal. The Department of Transportation's schedule of estimated completion progress for this project as required by that Standard Special Provision is as follows:

	<u>Fiscal Year</u>	<u>Progress (% of Dollar Value)</u>
2024	(7/01/23 - 6/30/24)	56% of Total Amount Bid
2025	(7/01/24 - 6/30/25)	44% of Total Amount Bid

The Contractor shall also furnish his own progress schedule in accordance with Article 108-2 of the *Standard Specifications*. Any acceleration of the progress as shown by the Contractor's progress schedule over the progress as shown above shall be subject to the approval of the Engineer.

U.S. DEPARTMENT OF TRANSPORTATION HOTLINE:

(11-22-94)

108-5

SP1 G100

To report bid rigging activities call: **1-800-424-9071**

The U.S. Department of Transportation (DOT) operates the above toll-free hotline Monday through Friday, 8:00 a.m. to 5:00 p.m. eastern time. Anyone with knowledge of possible bid rigging, bidder collusion, or other fraudulent activities should use the hotline to report such activities.

The hotline is part of the DOT's continuing effort to identify and investigate highway construction contract fraud and abuse is operated under the direction of the DOT Inspector General. All information will be treated confidentially and caller anonymity will be respected.

CARGO PREFERENCE ACT:

(2-16-16)

Privately owned United States-flag commercial vessels transporting cargoes are subject to the Cargo Preference Act (CPA) of 1954 requirements and regulations found in 46 CFR 381.7. Contractors are directed to clause (b) of 46 CFR 381.7 as follows:

- (b) Contractor and Subcontractor Clauses. "Use of United States-flag vessels: The contractor agrees-

“(1) To utilize privately owned United States-flag commercial vessels to ship at least 50 percent of the gross tonnage (computed separately for dry bulk carriers, dry cargo liners, and tankers) involved, whenever shipping any equipment, material, or commodities pursuant to this contract, to the extent such vessels are available at fair and reasonable rates for United States-flag commercial vessels.

(2) To furnish within 20 days following the date of loading for shipments originating within the United States or within 30 working days following the date of loading for shipments originating outside the United States a legible copy of a rated, 'on-board' commercial ocean bill-of-lading in English for each shipment of cargo described in paragraph (b) (1) of this section to both the Contracting Officer (through the prime contractor in the case of subcontractor bills-of-lading) and to the Division of National Cargo, Office of Market Development, Maritime Administration, Washington, DC 20590.

(3) To insert the substance of the provisions of this clause in all subcontracts issued pursuant to this contract."

EQUIPMENT IDLING GUIDELINES:

(1-19-21)

107

SP1 G096

Exercise reduced fuel consumption and reduced equipment emissions during the construction of all work associated with this contract. Employees engaged in the construction of this project should turn off vehicles when stopped for more than thirty (30) minutes and off-highway equipment should idle no longer than fifteen (15) consecutive minutes.

These guidelines for turning off vehicles and equipment when idling do not apply to:

1. Idling when queuing.
2. Idling to verify the vehicle is in safe operating condition.
3. Idling for testing, servicing, repairing or diagnostic purposes.
4. Idling necessary to accomplish work for which the vehicle was designed (such as operating a crane, mixing concrete, etc.).
5. Idling required to bring the machine system to operating temperature.
6. Emergency vehicles, utility company, construction, and maintenance vehicles where the engines must run to perform needed work.
7. Idling to ensure safe operation of the vehicle.
8. Idling when the propulsion engine is providing auxiliary power for other than heating or air conditioning. (such as hydraulic systems for pavers)

9. When specific traffic, safety, or emergency situations arise.
10. If the ambient temperature is less than 32 degrees Fahrenheit. Limited idling to provide for the safety of vehicle occupants (e.g. to run the heater).
11. If the ambient temperature is greater than 90 degrees Fahrenheit. Limited idling to provide for the safety of vehicle occupants of off-highway equipment (e.g. to run the air conditioning) no more than 30 minutes.
12. Diesel powered vehicles may idle for up to 30 minutes to minimize restart problems.

Any vehicle, truck, or equipment in which the primary source of fuel is natural gas or electricity is exempt from the idling limitations set forth in this special provision.

OUTSOURCING OUTSIDE THE USA:

(9-21-04) (Rev. 5-16-06)

SP1 G150

All work on consultant contracts, services contracts, and construction contracts shall be performed in the United States of America. No work shall be outsourced outside of the United States of America.

Outsourcing for the purpose of this provision is defined as the practice of subcontracting labor, work, services, staffing, or personnel to entities located outside of the United States.

The North Carolina Secretary of Transportation shall approve exceptions to this provision in writing.

AUTHORITY OF THE ENGINEER:

(01-30-14)

105-1

SPD 01-460

The Engineer for this project shall be the Division Engineer, Division 8, Division of Highways, North Carolina Department of Transportation, acting directly or through his duly authorized representative.

The Engineer will decide all questions which may arise as to the quality and acceptability of work performed and as to the rate of progress of the work; all questions which may arise as to the interpretation of the contract; and all questions as to the acceptable fulfillment of the contract on the part of the Contractor. His decision shall be final and he shall have executive authority to enforce and make effective such decisions and orders as the Contractor fails to carry out promptly.

PROSECUTION AND PROGRESS:

(3-16-10)

108

SPD 1-700

The Contractor will be required to prosecute the work in a continuous and uninterrupted manner from the time he begins the work until completion and final acceptance of the project. The Contractor will not be permitted to suspend his operations except for reasons beyond his control or except where the Engineer has authorized a suspension of the Contractor's operations in writing.

It is further the intent that the Contractor shall pursue the work diligently with workmen in sufficient numbers, abilities, and supervision, and with the equipment, materials, and methods of construction as may be required to complete the work described in the contract, or as may be amended, by the completion date and in accordance with Section 108 of the Standard Specifications.

The Contractor's vehicles and equipment shall not be parked within the State Highway System right of way overnight or at other times when work has been suspended unless approved by the

Engineer, and in no case within 30 feet of the edge of pavement. The Engineer may designate specific locations for parking equipment.

The Contractor shall adhere to all applicable regulations and follow accepted safety procedures when working in the vicinity of utilities in order to insure the safety of construction personnel and the public.

In the event that the Contractor's operations are suspended in violation of the above provisions, the sum of **Six Hundred (\$600.00)** will be charged to the contractor for each and every calendar day that such suspension takes place. The said amount is hereby agreed upon as liquidated damages. Liquidated damages chargeable due to suspension of the work will be additional to any liquidated damages that may become chargeable due to failure to complete the work by the completion date.

SUPERVISION BY CONTRACTOR:

At all times during the life of the project the Contractor shall provide one permanent employee who shall have the authority and capability for overall responsibility of the project and who shall be personally available at the work site within 24 hours notice. Such employee shall be fully authorized to conduct all business with the subcontractors, to negotiate and execute all supplemental agreements, and to execute the orders or directions of the Engineer.

At all times that work is actually being performed, the Contractor shall have present on the project one competent individual who is authorized to act in a supervisory capacity over all work on the project, including work subcontracted. The individual who has been so authorized shall be experienced in the type of work being performed and shall be fully capable of managing, directing, and coordinating the work; of reading and thoroughly understanding the contract; and receiving and carrying out directions from the Engineer or his authorized representatives. He shall be an employee of the Contractor unless otherwise approved by the Engineer.

The Contractor may, at his option, designate one employee to meet the requirements of both positions. However, whenever the designated employee is absent from the work site, an authorized individual qualified to act in a supervisory capacity on the project shall be present.

INSPECTION:

All work shall be subject to inspection by the Engineer at any time. Routinely, the Engineer will make periodic inspections of the completed work. It will be the responsibility of the Contractor to keep the Engineer informed of his proposed work plan and to submit written reports of work accomplished on a frequency to be determined by the Engineer.

SAFETY AND ACCIDENT PROTECTION:

In accordance with Article 107-21 of the Standard Specifications, the Contractor shall comply with all applicable Federal, State, and local laws, ordinances, and regulations governing safety, health, and sanitation, and shall provide all safeguards, safety devices, and protective equipment, and shall take any other needed actions, on his own responsibility that are reasonably necessary to protect the life and health of employees on the job and the safety of the public, and to protect property in connection with the performance of the work covered by the contract.

EXTENSION OF CONTRACT TIME:

Failure on the part of the Contractor to furnish bonds or certifications or to satisfy preliminary requirements necessary to issue the purchase order will not constitute grounds for extension of the contract time. If the Contractor has fulfilled all preliminary requirements for the issuance of a purchase order, and the purchase order authorization is not available by the date of availability, the Contractor shall be granted an extension equal to the number of calendar days the purchase order authorization is delayed after the date of availability.

NOTIFICATION OF OPERATIONS:

The Contractor shall notify the Engineer 48 hours in advance of beginning work on this project. The Contractor shall give the Engineer sufficient notice of all operations for any sampling or inspection of acceptance testing required.

RESPONSIBILITY FOR DAMAGE CLAIMS

In accordance with 107-14 of the Standard Specifications. The Contractor shall indemnify and save harmless the Board of Transportation and its members and the Department of Transportation and its officers, agents, and employees from all suits, actions, or claims of any character brought for any injury or damages received or sustained by any person, persons, or property by reason of any act of the Contractor, Subcontractor, its agents or employees, in the performance of the contract.

MOBILIZATION:

There will be no payment for mobilization of labor or equipment as it will be considered incidental to the bid items of this contract. The contractor shall be responsible for all costs or charges incurred in the operation and maintenance of the equipment during the performance of this contract.

PAYMENT AND RETAINAGE

The Contractor may submit requests for partial payments on a monthly basis, or other interval as approved by the Engineer. Compensation for all pay items shall be in accordance with the Standard Specifications. The amount of partial payments will be based on the work accomplished and accepted by the last day of the approved pay period.

Requests for payment shall be made by Contractor's Invoice. All invoice items and unit costs shall correspond to contract pay items. In the event of error or discrepancy in items or unit costs, the Department may return the invoice to the contractor for correction. The invoice shall be completely and legibly filled out with all appropriate information and shall be signed by an authorized representative of the Contractor.

All invoices shall be original and submitted to the Division Roadside Environmental Engineer for approval. Statements of all Subcontractor payments shall be included with invoices. These statements are to be submitted on the Subcontractor Payment Information Form (DBE-IS), they shall be original and in ink.

Payment will not be made until invoices and DBE-IS forms are received. Invoices should be received by the Department within 30 days of the completion of the work.

All requests for payment shall be submitted to:

Mr. Mark Thompson
Division Roadside Environmental Engineer
N.C. Department of Transportation
121 DOT Drive
Carthage, NC 28327

Due to the nature of the contract, no retainage will be withheld. However, the Department reserves the right to withhold payment for a specific location until after successful completion of the work as verified by the final inspection of that location.

All work or items, other than those listed on the Bid Form contained in the Contract Proposal, necessary to complete this work will be considered incidental in nature and no further compensation will be made.

Payment to the Contractor will be made only for the actual quantities of the various items that are completed and accepted in accordance with the terms of the contract. The advertised bid quantities are considered to be approximate only and are given as the basis for comparison of bids. The Department of Transportation may increase or decrease the quantity of any item or portion of the work as may be deemed necessary or expedient. Unless otherwise specified, all contract pay items will be produced, placed and paid in accordance with the Standard Specifications.

PROJECT SPECIAL PROVISIONS

ROADWAY

SELECTIVE TREE CUTTING

This contract is for cutting and removal of designated trees in the right of way in Hoke County – Fort Liberty, Division 8. See the tree list with quantity, road name, latitude and longitude below.

The Contractor is to cut the designated, marked trees in their entirety from within the right of way in accordance with these specifications. Trees shall be cut as close to the ground as possible, leaving the shortest possible stump. The trunks of each tree shall be cut into lengths no longer than six (6) feet, shall be placed no closer than ten (10) feet from the edge of pavement and shall not be stacked. All tree limbs and brush shall be removed from the trunk and shall be cut into lengths no longer than six (6) feet, shall be placed no closer than ten (10) feet from the edge of pavement and shall not be stacked. Debris shall not be placed in a ditch. **The Contractor must remove all cut trees and limbs from the right of way within 2 days of completion of cutting. Trees and limbs shall not be discarded on the right of way or in the forest along Fort Liberty roads.** The Contractor shall conduct his operations in such a manner to prevent injury to trees, shrubs, grass or legume ground cover, or other types of vegetation that are to remain growing, and to prevent damage to adjacent property.

The Contractor shall furnish all equipment in good operating condition and operated by properly trained and qualified personnel. The Contractor shall be responsible for all costs or charges incurred in the operation and maintenance of the equipment during the performance of this contract.

The Contractor is to provide all transportation to and from work sites and is to provide all saws, safety equipment, and miscellaneous supplies, signs and equipment to insure safe, and efficient operation. All such equipment and supplies are to be considered incidental items and will not be pay items.

Removal and disposal of all trimmings, laps, brush, or debris produced by the above operation shall be the responsibility of the Contractor. When chipping is used to dispose of trimmings, the Engineer may approve the spreading of chips along certain sections of highway right of way. **All other debris must be removed from the highway right of way before payment is made. No burning or burying of debris will be allowed on the highway right of way or in the forest along Fort Liberty roads.**

Measurement and Payment

The quantities of selective tree cutting to be paid for will be the number of trees which have been cut as specified herein.

Pay Item	Pay Unit
Select Tree Removal	Each

Number	Road Name	Category	Description	Latitude	Longitude	Creator
1	Plank	Tree Removal	5 tree	35.05137758	-79.34356419	klhammonds_NCDOT
2	Plank	Tree Removal	1 tree	35.04807888	-79.33251699	klhammonds_NCDOT
3	King	Tree Removal	2 tree	35.0537207	-79.33228169	klhammonds_NCDOT
4	King	Tree Removal	1 tree	35.05624962	-79.33358316	klhammonds_NCDOT
5	King	Tree Removal	3 tree	35.07249557	-79.3395805	klhammonds_NCDOT
6	King	Tree Removal	1 tree	35.07298314	-79.33965576	klhammonds_NCDOT
7	King	Tree Removal	7 tree	35.08939706	-79.34072462	klhammonds_NCDOT
8	King	Tree Removal	1 tree	35.08934546	-79.34066442	klhammonds_NCDOT
9	King	Tree Removal	9 tree	35.1105252	-79.34092731	klhammonds_NCDOT
10	King	Tree Removal	1 tree	35.11082825	-79.34153513	klhammonds_NCDOT
11	King	Tree Removal	11 tree	35.11089274	-79.34164765	klhammonds_NCDOT
12	King	Tree Removal	1 tree	35.11550795	-79.34269818	klhammonds_NCDOT
13	King	Tree Removal	1 tree	35.1221495	-79.34194976	klhammonds_NCDOT
14	King	Tree Removal	1 tree	35.12225961	-79.34190408	klhammonds_NCDOT
15	King	Tree Removal	3 tree	35.13386735	-79.3401073	klhammonds_NCDOT
16	King	Tree Removal	2 tree	35.14934023	-79.33380363	klhammonds_NCDOT
17	King	Tree Removal	3 tree	35.15184709	-79.34183794	klhammonds_NCDOT
18	King	Tree Removal	1 tree	35.14345365	-79.33790599	klhammonds_NCDOT
19	King	Tree Removal	1 tree	35.13025372	-79.34081717	klhammonds_NCDOT
20	King	Tree Removal	3 tree	35.12887762	-79.3409885	klhammonds_NCDOT
21	King	Tree Removal	5 tree	35.11732857	-79.34279577	klhammonds_NCDOT
22	King	Tree Removal	2 tree	35.11403789	-79.3427089	klhammonds_NCDOT
23	King	Tree Removal	2 tree	35.11056369	-79.34122382	klhammonds_NCDOT
24	King	Tree Removal	5 tree	35.11045669	-79.34111154	klhammonds_NCDOT
25	King	Tree Removal	8 tree	35.11054985	-79.34125037	klhammonds_NCDOT
26	King	Tree Removal	1 tree	35.10703334	-79.33853795	klhammonds_NCDOT
27	King	Tree Removal	9 tree	35.10400176	-79.33961967	klhammonds_NCDOT
28	King	Tree Removal	5 tree	35.08915017	-79.34077937	klhammonds_NCDOT
29	King	Tree Removal	1 tree	35.08947003	-79.34082674	klhammonds_NCDOT
30	King	Tree Removal	1 tree	35.08166111	-79.34032592	klhammonds_NCDOT
31	King	Tree Removal	1 tree	35.07239495	-79.33969346	klhammonds_NCDOT
32	King	Tree Removal	1 tree	35.06160643	-79.33644552	klhammonds_NCDOT
33	King	Tree Removal	8 tree	35.0566053	-79.33392983	klhammonds_NCDOT
34	Morrison bridge	Tree Removal	2 tree	35.1864674	-79.18696905	klhammonds_NCDOT
35	Morrison bridge	Tree Removal	1 tree	35.1882043	-79.18631098	klhammonds_NCDOT
36	Morrison bridge	Tree Removal	7 tree	35.18877374	-79.18594446	klhammonds_NCDOT
37	Manchester	Tree Removal	4 tree	35.15238581	-79.32892849	klhammonds_NCDOT
38	Manchester	Tree Removal	4 tree	35.15306639	-79.32768282	klhammonds_NCDOT
39	Manchester	Tree Removal	2 tree	35.15539599	-79.32367883	klhammonds_NCDOT
40	Manchester	Tree Removal	1 tree	35.15855891	-79.31434566	klhammonds_NCDOT
41	Manchester	Tree Removal	1 tree	35.15910439	-79.31134718	klhammonds_NCDOT
42	Manchester	Tree Removal	2 tree	35.16041793	-79.30490261	klhammonds_NCDOT
43	Manchester	Tree Removal	5 tree	35.16563707	-79.2945162	klhammonds_NCDOT
44	Manchester	Tree Removal	3 tree	35.16686414	-79.29269161	klhammonds_NCDOT
45	Manchester	Tree Removal	4 tree	35.1670693	-79.29207811	klhammonds_NCDOT
46	Manchester	Tree Removal	1 tree	35.16819398	-79.29016565	klhammonds_NCDOT
47	Manchester	Tree Removal	1 tree	35.16869112	-79.28922155	klhammonds_NCDOT
48	Manchester	Tree Removal	7 tree	35.1695805	-79.28750661	klhammonds_NCDOT
49	Manchester	Tree Removal	1 tree	35.16962091	-79.28736362	klhammonds_NCDOT
50	Manchester	Tree Removal	3 tree	35.17061703	-79.28556805	klhammonds_NCDOT
51	Manchester	Tree Removal	2 tree	35.17490468	-79.27952795	klhammonds_NCDOT
52	Manchester	Tree Removal	2 tree	35.1751961	-79.27915521	klhammonds_NCDOT
53	Manchester	Tree Removal	3 tree	35.17631135	-79.2776953	klhammonds_NCDOT
54	Manchester	Tree Removal	1 tree	35.18006386	-79.27257208	klhammonds_NCDOT
55	Manchester	Tree Removal	1 tree	35.18476641	-79.26439795	klhammonds_NCDOT
56	Manchester	Tree Removal	2 tree	35.18429775	-79.24999078	klhammonds_NCDOT

57	Manchester	Tree Removal	1	tree	35.18373229	-79.24793175	klhammonds_NCDOT
58	Manchester	Tree Removal	2	tree	35.18018189	-79.23477588	klhammonds_NCDOT
59	Manchester	Tree Removal	2	tree	35.18415566	-79.21721549	klhammonds_NCDOT
60	Manchester	Tree Removal	12	tree	35.18405312	-79.21649203	klhammonds_NCDOT
61	Manchester	Tree Removal	1	tree	35.18402584	-79.21584396	klhammonds_NCDOT
62	Manchester	Tree Removal	1	tree	35.18387898	-79.21526898	klhammonds_NCDOT
63	Manchester	Tree Removal	3	tree	35.18366221	-79.21373451	klhammonds_NCDOT
64	Manchester	Tree Removal	2	tree	35.18353418	-79.21272543	klhammonds_NCDOT
65	Manchester	Tree Removal	8	tree	35.18344482	-79.21221123	klhammonds_NCDOT
66	Manchester	Tree Removal	4	tree	35.18338098	-79.21179368	klhammonds_NCDOT
67	Manchester	Tree Removal	3	tree	35.1855906	-79.2003178	klhammonds_NCDOT
68	Manchester	Tree Removal	1	tree	35.18558994	-79.19120174	klhammonds_NCDOT
69	Manchester	Tree Removal	5	tree	35.18551877	-79.1909393	klhammonds_NCDOT
70	Manchester	Tree Removal	3	tree	35.18330615	-79.18119237	klhammonds_NCDOT
71	Manchester	Tree Removal	4	tree	35.17841659	-79.16728527	klhammonds_NCDOT
72	Manchester	Tree Removal	1	tree	35.17401055	-79.16445177	klhammonds_NCDOT
73	Manchester	Tree Removal	6	tree	35.17312283	-79.16388528	klhammonds_NCDOT
74	Manchester	Tree Removal	1	tree	35.16665707	-79.14798473	klhammonds_NCDOT
75	Manchester	Tree Removal	3	tree	35.1860947	-79.19300774	klhammonds_NCDOT
76	Manchester	Tree Removal	8	tree	35.18598069	-79.19518215	klhammonds_NCDOT
77	Manchester	Tree Removal	7	tree	35.18562201	-79.20020387	klhammonds_NCDOT
78	Manchester	Tree Removal	1	tree	35.1842538	-79.21733223	klhammonds_NCDOT
79	Manchester	Tree Removal	1	tree	35.18443506	-79.2653648	klhammonds_NCDOT

LONG-ARM MOWING WITH MULCHING/PICKUP

The Contractor shall furnish to the Department of Transportation the fully operated equipment described in this contract as needed for vegetation trimming using long arm mowers with mulching/pickup along designated routes within **Hoke County - Fort Liberty**.

The Contractor shall furnish equipment in good working condition and operated by properly trained and qualified personnel. The personnel operating the equipment shall be employees of the Contractor or approved Subcontractor and the Contractor shall be responsible for all operators during the performance of the contract. The personnel shall be subject to the directions of the Department of Transportation. The Department of Transportation may refuse delivery or may reject any equipment found to be defective and/or inadequately operated.

The Division Roadside Environmental Engineer will select and coordinate the locations to be mowed and provide a map of mowing routes to the contractor. All work must be accomplished during daylight hours. No night work is permitted. No work permitted on Sundays or as directed by the Engineer.

Units of the Bid Sheets are for bid evaluation only and do not reflect purchase order limits. Purchase order quantities will be based on actual need. Section 104-5 of the 2024 Standard Specifications will not be applicable. The Engineer reserves the right to make, at any time during the work, such changes in quantities as necessary to satisfactorily complete the project.

The Contractor shall exercise caution not to damage or destroy private property such as plantings or landscaping unless otherwise directed.

The Contractor shall notify the Engineer at the start of operations and shall keep the Engineer informed of the proposed work plan. The Contractor shall submit written reports of work accomplished on a weekly basis, unless otherwise directed.

All work shall be subject to inspection by the Engineer at any time. The Engineer will make periodic inspections of the completed work. It is intended that the work will be completed in a neat, workmanlike manner. Areas which are gapped or rolled down and uncut will not be considered acceptable.

The Contractor shall incur Liquidated Damages in the amount of **SIX Hundred Dollars (\$600.00)** per incident for failing to immediately remove any grass, brush, or debris deposited into the roadway, which includes travel lanes, shoulders, bulb-outs, ditches, and drainage structures, as a result of the Contractor’s operations in order to eliminate any hazards.

All damage to turf shall be repaired within fourteen (14) days of notification. If repairs are not made within stated time NCDOT will repair these areas and deduct the cost from the Contractor’s next invoice.

Equipment

The Contractor shall provide the following functional and operating equipment each cycle in the performance of mowing for this contract:

- Long arm mowers-----2
- Shadow Truck-----1

This is the minimum amount of equipment specified for this project. Additional equipment may be required to successfully fulfil the contract.

All long arm mowers provided under this agreement shall be hydraulic powered and shall reach a minimum of twenty feet (20 ft) from the center of the tractor. Mower hydraulics shall be controlled from within the driver/passenger compartment. The tractor shall have sufficient horsepower to operate the mower per mower manufacturer recommendations and shall be capable of cutting up

to a 5" diameter tree or tree limb. The Department will not be responsible for damage to the Contactors' equipment.

Mowers are to be equipped with shields, which preclude foreign objects from being thrown out from the cutting unit enclosures. Tractors shall be equipped so as to conform to the prevailing Occupational Safety Health Act Standards. All tractors shall be equipped with one (1) light bar mounted on top of the cab. The width of the bar shall be seventeen (17) inches or greater but shall not exceed safe mounting limits of the cab. The bar's light source may be a series of rotating quartz-halogen, incandescent, or LED bulbs; stroboscopic lamps; or static programmable LED. The Engineer may require an alternate pattern should the one chosen be deemed unsafe, inconsistent, or inadequate. The light source shall be amber in color as permitted by N.C.G.S § 20-130.2. The light bar shall be visible from all directions. All tractors shall be equipped with one (1) perimeter light mounted on the left rear fender, and one (1) perimeter light mounted on the right rear fender. These lights shall be amber in color. All equipment shall also be equipped with reverse gear warning devices.

The Contractor must furnish, mount, and maintain a W10-11 or W10-11A "Caution Mower" sign on the rear of each mower such that they can be easily read by motorists approaching from the rear. Both sign types are black lettering over a fluorescent orange background. The sign should have a minimum clearance of one (1) foot from the ground to the bottom of the sign. The sign must not obstruct any safety lighting.

The Contractor's company name, identification number, and telephone number shall be prominently displayed on each tractor.

The Contractor shall furnish all equipment in good operating condition and operated by properly trained and qualified personnel. There will be **no payment for mobilization** of labor and equipment, as it will be **considered incidental** to the bid items of this contract. The Contractor shall be responsible for all costs or charges incurred in the operation and maintenance of the equipment during the performance of this contract.

The Contractor must demonstrate to the satisfaction of the Engineer that the mowing equipment to be used in the work is in good working condition (i.e., no excessive fluid leaks; blades sharpened and in good condition) and suitable for performing the work required. All tractors shall have sufficient horsepower to operate their mowers per manufacturer recommendations. All tractor tires shall have adequate tread depth to perform the work required. All equipment safety devices as were originally designed/provided by the manufacturer shall be in place. Tractors shall be equipped with reverse gear/backup warning devices that are in a working condition and audible.

The Engineer may reject any equipment that is not operating in a satisfactory manner. Reasons for rejection shall include but not be limited to excessive leaks, tractors that cannot be operated in both forward and reverse gear, audible backup alarms and mower attachments that are not capable of acceptable mowing. The Contractor shall make arrangements for equipment replacement/repair as needed to satisfy the contract objective. No extension in contract times will be allowed due to rejected equipment.

The Contractor shall be responsible for the equipment provided in this contract at all times and at all locations during the term of the contract. The Contractor shall have no claim against the Department of Transportation for any expense involving damage or loss to the Contractor's equipment (including vandalism, theft, fire and acts of God, etc.) arising out of, or relating to, work performed under this agreement.

Long Arm Mowing

All routes shall be mowed to the top of the cut slope, to the bottom of the fill slope, or to the limit of the equipment. Vegetation hanging over the slope or roadway shall be mowed to the limit of the equipment. All vegetation five (5) inches in diameter or less shall be cut. Tree limbs shall be cut

back to the existing trunk line of trees larger than five (5) inches. Ground vegetation shall be cut to a height of no greater than six (6) inches. Cut vegetation shall be cleaned up or mulched. All brush or debris which falls onto the roadway shall be immediately removed by the Contractor.

Mulching (Not in Maintained Yards/Properties)

The Contractor shall mulch all cuttings to a size not greater than 1 inch wide and 4 inches long. Mulching can be achieved by the use of the long arm mower, chipper or other method as approved by the Engineer.

All equipment shall be equipped with shields/guards which precludes foreign objects from being thrown out from the cutting unit. The Contractor shall be responsible for all costs or charges incurred in the operation and maintenance of the equipment during the term of the contract including, but not limited to; fuel, oil, equipment repairs, etc. Mulching shall be considered incidental to the long arm mowing operation and the Contractor will be compensated for any equipment operation and incidentals at the hourly rate defined elsewhere in this contract.

Debris Pickup (Within Limits of Maintained Yards/Properties)

The Contractor will be required to pick up and remove all cuttings that are within the limits of a maintained yard/property. Pickup/Removal shall be considered incidental to the long arm mowing operation and the Contractor will be compensated for all pickup/removal at the hourly rate defined elsewhere in this contract.

Truck Mounted Attenuator and Shadow Truck

Along designated divided primary routes, provide a truck mounted attenuator in accordance with Articles 1089-9, 1165-2, and 1165-3 of the *2024 Standard Specifications*.

Along designated primary undivided and secondary routes, provide and maintain a truck and operator to shadow the long arm mowing operation. Shadow trucks shall be performance worthy by visual and operational inspection during a times of operation. This truck provides warning and protection for slow moving long arm mowing tractors. *Shadow Trucks* shall be equipped with a minimum of two (2) outside blinking amber lights visible from both directions and one (1) cab mounted amber rotating light, visible from all directions. The truck shall have the company name prominently displayed on each side. During operations, the shadow vehicle shall also have a “**MOWING AHEAD**” sign mounted and maintained upon the rear of the vehicle.

Measurement and Payment

Long Arm Mowing shall be measured and paid as the actual number of shoulder miles acceptably mowed. Such price and payment will be full compensation for all work including, but not limited to, furnishing labor an equipment to mow. No separate payment will be made for traffic control, mulching, debris removal or disposal.

Payment will be made under:

Pay Item

Two (2) Fully Operated Long Arm Mowing Tractors and One (1) Shadow Truck with Traffic Control.

Pay Unit

Shoulder Mile

MOWING LIMITS- TOE OF SLOPE

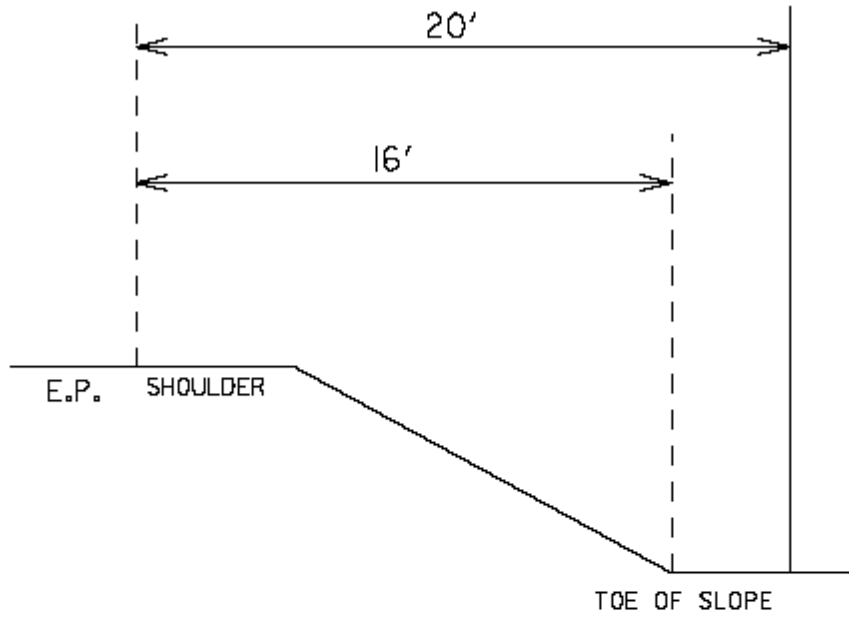

MOWING LIMITS- 20 FEET

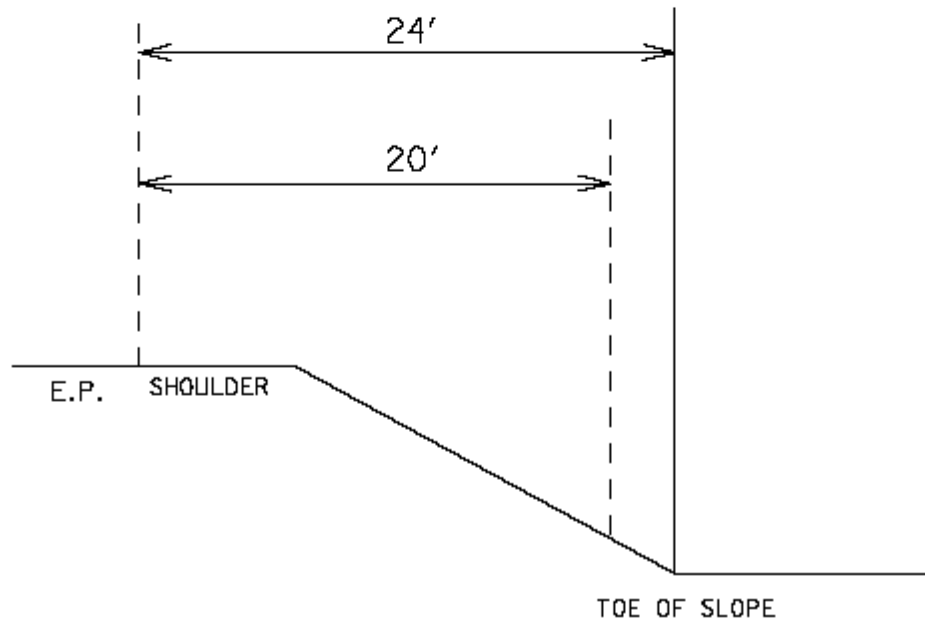

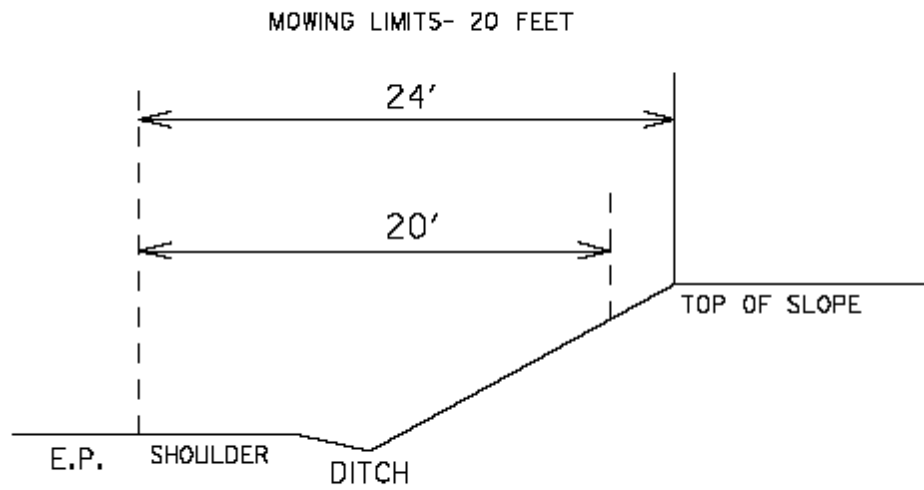
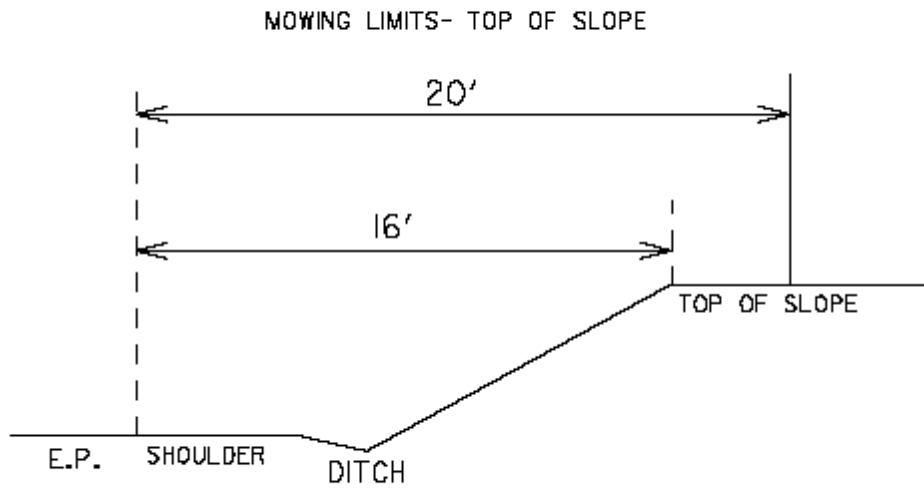

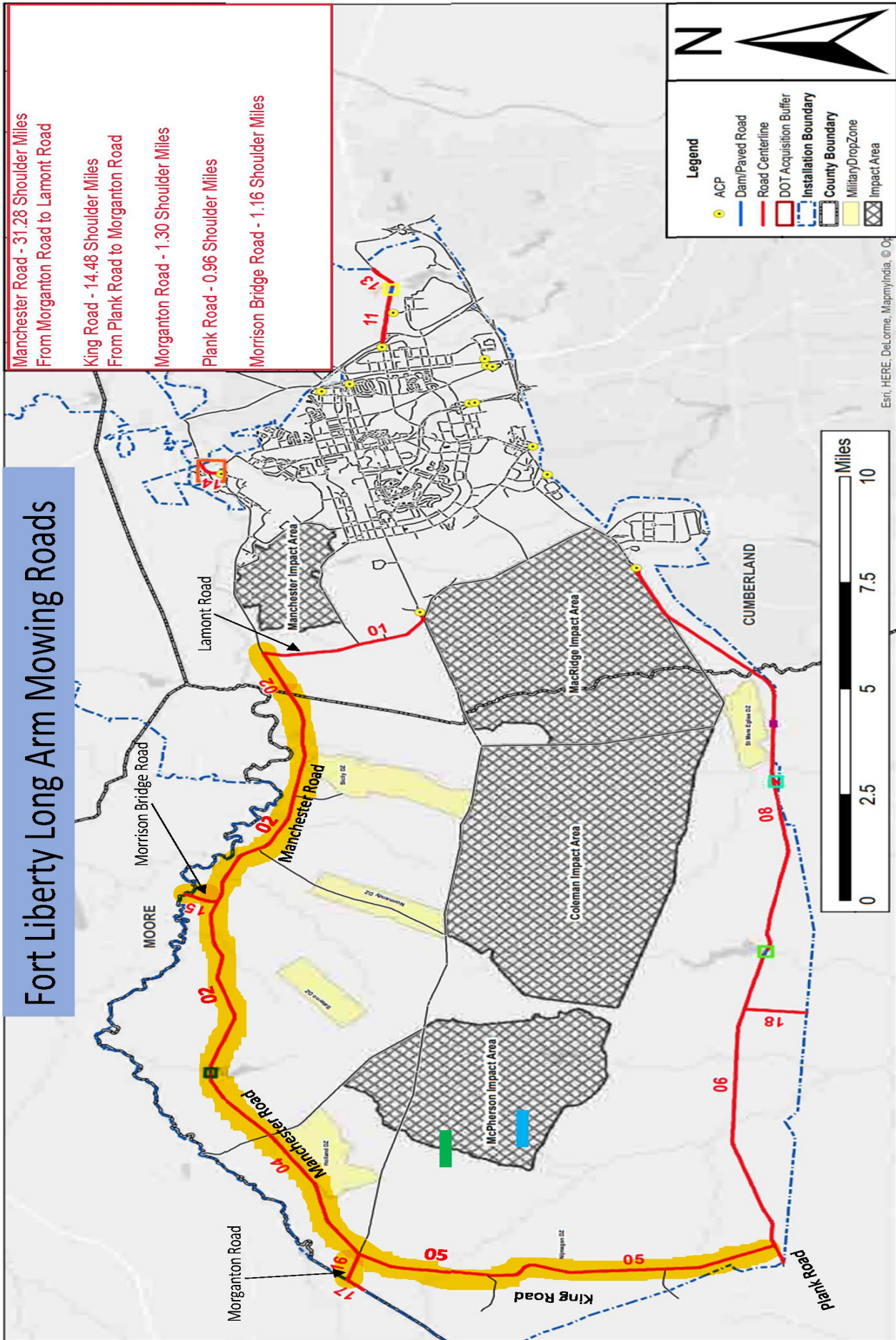

EQUIPMENT REQUIREMENTS

The Contractor shall furnish equipment of sufficient type, capacity, and quantity to safely and efficiently perform the work. All vehicles used by the Contractor must be performance worthy by visual and operational inspection. The Contractor shall display and telephone number the company name on each piece of equipment.

All vehicles, including trailers, used in the removal operation should be properly equipped with lighting per Roadway Standard Drawing 1165.01 Sheet 1 of 1. Trailers shall have rear mounted strobe lights, mounted as high as possible to enhance visibility.

The Contractor shall be responsible for the equipment provided in this contract at all times and at all locations during the term of the contract. The Contractor shall have no claim against the Department of Transportation for any expense involving damage or loss to the Contractor's equipment (including vandalism, theft, fire and acts of God, etc.) arising out of, or relating to, work performed under this contract.

The safety of the public and the convenience of traffic shall be regarded as prime importance. The Contractor shall operate the equipment in a safe manner so as not to create a hazard to the traveling public. Crossing lanes of traffic and erratic driving will be strictly prohibited.

Signs, lights, safety, and other traffic control items are not a pay item but are considered incidental to other contract items and the Contractor is expected to provide these items.

TRAFFIC CONTROL:

The Contractor shall maintain traffic during construction and provide, install, and maintain all traffic control devices in accordance with these project guidelines, the Project Special Provisions, North Carolina Department of Transportation 2024 *Standard Specifications for Roads and Structures*, and the current edition of the *Manual of Uniform Traffic Control Devices (MUTCD)*. Failure to comply with any of the requirements for safety and traffic control of this contract shall result in suspension of work as provided in NCDOT 2024 *Standard Specifications* Section 108-7.

The Contractor shall utilize complete and proper traffic controls and traffic control devices during all operations. All traffic control and traffic control devices required for any operation shall be functional and in place prior to the commencement of that operation. Signs for temporary operations shall be removed during periods of inactivity. The Contractor is required to leave the project in a manner that will be safe to the traveling public, and which will not impede motorists.

Traffic movements through lane closures on roads with two- way traffic (Two-Lane) shall be controlled by flaggers stationed at each end of the work zone. In situations where sight distance is limited, the Contractor shall provide additional means of controlling traffic, including, but not limited to, two- way radios, pilot vehicles, or additional flaggers.

Flaggers shall be competent personnel, adequately trained in flagging procedures, and furnished with proper safety devices and equipment, including, but not limited to, safety vests and stop/slow paddles.

All personnel when working in traffic areas or areas in close proximity to traffic shall wear an approved safety vest, or shirt or jacket and hat or helmet which meets the color requirements of the *Manual of Uniform Traffic Control Devices (MUTCD)*.

The work zone sign shall be a portable sign 48" x 48" and stand specifically designed for one another, and should be 5 feet off the ground (refer to NCDOT 2024 Roadway Standard Drawing 1110.02) Signs shall be composite, aluminum or retro-reflective roll-up (Non-reflective Mesh Signs will not be accepted). It should be mounted 3' minimum from travel lane of the right shoulder or in the median in advance of the long arm mowing operation and should be relocated regularly to maintain a work zone of 2-mile maximum length. Care should be taken that this sign is displayed only while long arm mowing work is underway.

In accordance with NCDOT 2024 Standard Specifications 107-21, the Contractor shall comply with all applicable Federal, State and local laws, ordinances and regulations governing safety, health and sanitation and shall provide all safeguards, safety devices, protective equipment and shall take any other needed actions, on his own responsibility that are reasonably necessary to protect the life and health of employees of the job and the safety of the public, and to protect property on connection with the performance of the work covered by the contract.

There will be no payment for Traffic Control as it will be considered incidental to the bid items of this contract. The contractor shall be responsible for all costs or charges incurred with the erecting and maintenance of the traffic control during the performance of this contract.

The Contractor's vehicles and equipment shall not be parked within the State Highway System right of way overnight or at other times when work has been suspended unless approved by the Engineer, and in no case within 30 feet of the edge of pavement. The Engineer may designate specific locations for parking equipment.

Traffic Control will be incidental to the work and will be included in the unit bid price for the other items included in the contract.

The liquidated damages for failing to place signs before commencement of operations is Two Hundred Fifty Dollars (\$250.00) per incident. All signs shall be clean, legible, and in good condition as determined by the Engineer.

In addition, the Contractor shall incur immediate Liquidated Damages in the amount of Two Hundred Fifty Dollars (\$250.00) each occurrence for failure to provide operational lighting and signage on all equipment as specified.

SAFETY VESTS

All Contractor's personnel, all subcontractors and their personnel, and any material suppliers and their personnel, must wear a reflective safety vest or outer garment meeting ANSI/ISEA 107-2004 Class 2 standards at all times while on the project.

Failure to comply with this provision may result in a fine of One Hundred Dollars (\$100.00) for each occurrence.

STANDARD SPECIAL PROVISION**AVAILABILITY OF FUNDS – TERMINATION OF CONTRACTS**

(5-20-08)(Rev. 1-16-24)

Z-2

General Statute 143C-6-11. (h) Highway Appropriation is hereby incorporated verbatim in this contract as follows:

(h) Amounts Encumbered. – Transportation project appropriations may be encumbered in the amount of allotments made to the Department of Transportation by the Director for the estimated payments for transportation project contract work to be performed in the appropriation fiscal year. The allotments shall be multiyear allotments and shall be based on estimated revenues and shall be subject to the maximum contract authority contained in *General Statute 143C-6-11(c)*. Payment for transportation project work performed pursuant to contract in any fiscal year other than the current fiscal year is subject to appropriations by the General Assembly. Transportation project contracts shall contain a schedule of estimated completion progress, and any acceleration of this progress shall be subject to the approval of the Department of Transportation provided funds are available. The State reserves the right to terminate or suspend any transportation project contract, and any transportation project contract shall be so terminated or suspended if funds will not be available for payment of the work to be performed during that fiscal year pursuant to the contract. In the event of termination of any contract, the contractor shall be given a written notice of termination at least 60 days before completion of scheduled work for which funds are available. In the event of termination, the contractor shall be paid for the work already performed in accordance with the contract specifications.

Payment will be made on any contract terminated pursuant to the special provision in accordance with Subarticle 108-13(D) of the *Standard Specifications*.

STANDARD SPECIAL PROVISION**ERRATA**

(1-16-24)

Z-4

Revise the *2024 Standard Specifications* as follows:

Division 3

Page 3-5, Article 305-2 MATERIALS, after line 16, replace " 1032-3(A)(7)" with "1032-3" and add the item "Galvanized Corrugated Steel Pipe" with Section "1032-3".

Page 3-6, Article 310-2 MATERIALS, after line 9, add the item "Galvanized Corrugated Steel Pipe" with Section "1032-3".

Division 9

Page 9-17, Article 904-4 MEASUREMENT AND PAYMENT, prior to line 1, replace " Sign Erection, Relocate Type (Ground Mounted)" with "Sign Erection, Relocate Type ___ (Ground Mounted)".

Division 10

Page 10-51, Article 1024-4 WATER, prior to line 1, delete the "unpopulated blank row" in Table 1024-2 between "Time of set, deviation from control" and "Chloride Ion Content, Max.".

Page 10-170, Subarticle 1081-1(C) Requirements, line 4, replace "maximum" with "minimum".

Division 11

Page 11-15, Article 1160-4 MEASUREMENT AND PAYMENT, line 24, replace "Where barrier units are moved more than one" with "Where barrier units are moved more than once".

Division 15

Page 15-10, Article 1515-4 MEASUREMENT AND PAYMENT, lines 11, replace " All piping" with "All labor, the manhole, other materials, excavation, backfilling, piping".

Division 16

Page 16-14, Article 1633-5 MEASUREMENT AND PAYMENT, line 20-24 and prior to line 25, delete and replace with the following " *Flocculant* will be measured and paid in accordance with Article 1642-5 applied to the temporary rock silt checks."

Page 16-3, Article 1609-2 MATERIALS, after line 26, replace "Type 4" with "Type 4a".

Page 16-25, Article 1644-2 MATERIALS, after line 22, replace "Type 4" with "Type 4a".

STANDARD SPECIAL PROVISION**PLANT AND PEST QUARANTINES****(Imported Fire Ant, Gypsy Moth, Witchweed, Emerald Ash Borer, Guava Root Knot Nematode, And Other Noxious Weeds)**

(3-18-03) (Rev. 5-21-19)

Z-04a

Within Quarantined Area

This project may be within a county regulated for plant and/or pests. If the project or any part of the Contractor's operations is located within a quarantined area, thoroughly clean all equipment prior to moving out of the quarantined area. Comply with federal/state regulations by obtaining a certificate or limited permit for any regulated article moving from the quarantined area.

Originating in a Quarantined County

Obtain a certificate or limited permit issued by the N.C. Department of Agriculture/United States Department of Agriculture. Have the certificate or limited permit accompany the article when it arrives at the project site.

Contact

Contact the N.C. Department of Agriculture/United States Department of Agriculture at 1-800-206-9333, 919-707-3730, or <https://www.ncagr.gov/plantindustry/Plant/quaran/table2.htm> to determine those specific project sites located in the quarantined area or for any regulated article used on this project originating in a quarantined county.

Regulated Articles Include

1. Soil, sand, gravel, compost, peat, humus, muck, and decomposed manure, separately or with other articles. This includes movement of articles listed above that may be associated with cut/waste, ditch pulling, and shoulder cutting.
2. Plants with roots including grass sod.
3. Plant crowns and roots.
4. Bulbs, corms, rhizomes, and tubers of ornamental plants.
5. Hay, straw, fodder, and plant litter of any kind.
6. Clearing and grubbing debris.
7. Used agricultural cultivating and harvesting equipment.
8. Used earth-moving equipment.
9. Any other products, articles, or means of conveyance, of any character, if determined by an inspector to present a hazard of spreading imported fire ant, gypsy moth, witchweed, emerald ash borer, guava root knot nematode, or other noxious weeds.

STANDARD SPECIAL PROVISION**MINIMUM WAGES**

(7-21-09)

Z-5

FEDERAL: The Fair Labor Standards Act provides that with certain exceptions every employer shall pay wages at the rate of not less than SEVEN DOLLARS AND TWENTY FIVE CENTS (\$7.25) per hour.

STATE: The North Carolina Minimum Wage Act provides that every employer shall pay to each of his employees, wages at a rate of not less than SEVEN DOLLARS AND TWENTY FIVE CENTS (\$7.25) per hour.

The minimum wage paid to all skilled labor employed on this contract shall be SEVEN DOLLARS AND TWENTY FIVE CENTS (\$7.25) per hour.

The minimum wage paid to all intermediate labor employed on this contract shall be SEVEN DOLLARS AND TWENTY FIVE CENTS (\$7.25) per hour.

The minimum wage paid to all unskilled labor on this contract shall be SEVEN DOLLARS AND TWENTY FIVE CENTS (\$7.25) per hour.

This determination of the intent of the application of this act to the contract on this project is the responsibility of the Contractor.

The Contractor shall have no claim against the Department of Transportation for any changes in the minimum wage laws, Federal or State. It is the responsibility of the Contractor to keep fully informed of all Federal and State Laws affecting his contract.

STANDARD SPECIAL PROVISION**TITLE VI AND NONDISCRIMINATION:**

(6-28-77)(Rev 1/16/2024)

Z-6

The North Carolina Department of Transportation is committed to carrying out the U.S. Department of Transportation's policy of ensuring nondiscrimination in the award and administration of contracts.

The provisions of this section related to United States Department of Transportation (US DOT) Order 1050.2A, Title 49 Code of Federal Regulations (CFR) part 21, 23 United States Code (U.S.C.) 140 and 23 CFR part 200 (or 49 CFR 303, 49 U.S.C. 5332 or 49 U.S.C. 47123) are applicable to all North Carolina Department of Transportation (NCDOT) contracts and to all related subcontracts, material supply, engineering, architectural and other service contracts, regardless of dollar amount. Any Federal provision that is specifically required not specifically set forth is hereby incorporated by reference.

(1) Title VI Assurances (USDOT Order 1050.2A, Appendix A)

During the performance of this contract, the contractor, for itself, its assignees, and successors in interest (hereinafter referred to as the "contractor") agrees as follows:

(a) Compliance with Regulations

The contractor (hereinafter includes consultants) shall comply with the Acts and the Regulations relative to Nondiscrimination in Federally-assisted programs of the U.S. Department of Transportation, Federal Highway Administration (FHWA), as they may be amended from time to time, which are herein incorporated by reference and made a part of this contract.

(b) Nondiscrimination

The contractor, with regard to the work performed by it during the contract, shall not discriminate on the grounds of race, color, or national origin in the selection and retention of subcontractors, including procurements of materials and leases of equipment. The contractor shall not participate directly or indirectly in the discrimination prohibited by the Acts and the Regulations, including employment practices when the contract covers any activity, project, or program set forth in Appendix B of 49 CFR Part 21.

(c) Solicitations for Subcontractors, Including Procurements of Materials and Equipment

In all solicitations, either by competitive bidding, or negotiation made by the contractor for work to be performed under a subcontract, including procurements of materials, or leases of equipment, each potential subcontractor or supplier shall be notified by the contractor of the contractor's obligations under this contract and the Acts and the Regulations relative to Nondiscrimination on the grounds of race, color, or national origin.

(d) Information and Reports

The contractor shall provide all information and reports required by the Acts, the Regulations, and directives issued pursuant thereto and shall permit access to its books, records, accounts, other sources of information, and its facilities as may be determined

by the Recipient or the FHWA to be pertinent to ascertain compliance with such Acts, Regulations, and instructions. Where any information required of a contractor is in the exclusive possession of another who fails or refuses to furnish the information, the contractor shall so certify to the Recipient or the FHWA, as appropriate, and shall set forth what efforts it has made to obtain the information.

(e) Sanctions for Noncompliance:

In the event of a contractor's noncompliance with the Non-discrimination provisions of this contract, the Recipient will impose such contract sanctions as it and/or the FHWA may determine to be appropriate, including, but not limited to:

- (i) Withholding payments to the contractor under the contract until the contractor complies; and/or
- (ii) Cancelling, terminating, or suspending a contract, in whole or in part.

(f) Incorporation of Provisions

The contractor shall include the provisions of paragraphs (a) through (f) in every subcontract, including procurements of materials and leases of equipment, unless exempt by the Acts, the Regulations and directives issued pursuant thereto. The contractor shall take action with respect to any subcontract or procurement as the Recipient or the FHWA may direct as a means of enforcing such provisions including sanctions for noncompliance. Provided, that if the contractor becomes involved in, or is threatened with litigation by a subcontractor, or supplier because of such direction, the contractor may request the Recipient to enter into any litigation to protect the interests of the Recipient. In addition, the contractor may request the United States to enter into the litigation to protect the interests of the United States.

(2) Title VI Nondiscrimination Program (23 CFR 200.5(p))

The North Carolina Department of Transportation (NCDOT) has assured the USDOT that, as a condition to receiving federal financial assistance, NCDOT will comply with Title VI of the Civil Rights Act of 1964 and all requirements imposed by Title 49 CFR part 21 and related nondiscrimination authorities to ensure that no person shall, on the ground of race, color, national origin, limited English proficiency, sex, age, or disability (including religion/creed or income-level, where applicable), be excluded from participation in, be denied the benefits of, or be subjected to discrimination under any programs, activities, or services conducted or funded by NCDOT. Contractors and other organizations under contract or agreement with NCDOT must also comply with Title VI and related authorities, therefore:

- (a) During the performance of this contract or agreement, contractors (e.g., subcontractors, consultants, vendors, prime contractors) are responsible for complying with NCDOT's Title VI Program. Contractors are not required to prepare or submit Title VI Programs. To comply with this section, the prime contractor shall:
 - 1. Post NCDOT's Notice of Nondiscrimination and the Contractor's own Equal Employment Opportunity (EEO) Policy in conspicuous locations accessible to all employees, applicants and subcontractors on the jobsite.
 - 2. Physically incorporate the required Title VI clauses into all subcontracts on federally-assisted and state-funded NCDOT projects, and ensure inclusion by subcontractors into all lower-tier subcontracts.

3. Required Solicitation Language. The Contractor shall include the following notification in all solicitations for bids and requests for work or material, regardless of funding source:

“The North Carolina Department of Transportation, in accordance with the provisions of Title VI of the Civil Rights Act of 1964 (78 Stat. 252, 42 U.S.C. §§ 2000d to 2000d-4) and the Regulations, hereby notifies all bidders that it will affirmatively ensure that any contract entered into pursuant to this advertisement, disadvantaged business enterprises will be afforded full and fair opportunity to submit bids in response to this invitation and will not be discriminated against on the grounds of race, color, or national origin in consideration for an award. In accordance with other related nondiscrimination authorities, bidders and contractors will also not be discriminated against on the grounds of sex, age, disability, low-income level, creed/religion, or limited English proficiency in consideration for an award.”
 4. Physically incorporate the FHWA-1273, in its entirety, into all subcontracts and subsequent lower tier subcontracts on Federal-aid highway construction contracts only.
 5. Provide language assistance services (i.e., written translation and oral interpretation), free of charge, to LEP employees and applicants. Contact NCDOT OCR for further assistance, if needed.
 6. For assistance with these Title VI requirements, contact the NCDOT Title VI Nondiscrimination Program at 1-800-522-0453.
- (b) Subrecipients (e.g. cities, counties, LGAs, planning organizations) may be required to prepare and submit a Title VI Plan to NCDOT, including Title VI Assurances and/or agreements. Subrecipients must also ensure compliance by their contractors and subrecipients with Title VI. (23 CFR 200.9(b)(7))
 - (c) If reviewed or investigated by NCDOT, the contractor or subrecipient agrees to take affirmative action to correct any deficiencies found within a reasonable time period, not to exceed 90 calendar days, unless additional time is granted by NCDOT. (23 CFR 200.9(b)(15))
 - (d) The Contractor is responsible for notifying subcontractors of NCDOT’s External Discrimination Complaints Process.
 1. Applicability

Title VI and related laws protect participants and beneficiaries (e.g., members of the public and contractors) from discrimination by NCDOT employees, subrecipients and contractors, regardless of funding source.
 2. Eligibility

Any person—or class of persons—who believes he/she has been subjected to discrimination based on race, color, national origin, Limited English Proficiency (LEP), sex, age, or disability (and religion in the context of employment, aviation, or transit) may file a written complaint. The law also prohibits intimidation or retaliation of any sort.
 3. Time Limits and Filing Options

Complaints may be filed by the affected individual(s) or a representative and must be filed no later than 180 calendar days after the following:

- (i) The date of the alleged act of discrimination; or
- (ii) The date when the person(s) became aware of the alleged discrimination; or
- (iii) Where there has been a continuing course of conduct, the date on which that conduct was discontinued or the latest instance of the conduct.

Title VI and related discrimination complaints may be submitted to the following entities:

- North Carolina Department of Transportation, Office of Civil Rights, Title VI Program, 1511 Mail Service Center, Raleigh, NC 27699-1511; toll free 1-800-522-0453
- Federal Highway Administration, North Carolina Division Office, 310 New Bern Avenue, Suite 410, Raleigh, NC 27601, 919-747-7010
- US Department of Transportation, Departmental Office of Civil Rights, External Civil Rights Programs Division, 1200 New Jersey Avenue, SE, Washington, DC 20590; 202-366-4070

4. Format for Complaints

Complaints must be in writing and signed by the complainant(s) or a representative, and include the complainant’s name, address, and telephone number. Complaints received by fax or e-mail will be acknowledged and processed. Allegations received by telephone will be reduced to writing and provided to the complainant for confirmation or revision before processing. Complaints will be accepted in other languages, including Braille.

5. Discrimination Complaint Form

Contact NCDOT Civil Rights to receive a full copy of the Discrimination Complaint Form and procedures.

6. Complaint Basis

Allegations must be based on issues involving race, color, national origin (LEP), sex, age, disability, or religion (in the context of employment, aviation or transit). “Basis” refers to the complainant’s membership in a protected group category.

**TABLE 103-1
COMPLAINT BASIS**

Protected Categories	Definition	Examples	Applicable Nondiscrimination Authorities
Race and Ethnicity	An individual belonging to one of the accepted racial groups; or the perception, based usually on physical characteristics that a person is a member of a racial group	Black/African American, Hispanic/Latino, Asian, American Indian/Alaska Native, Native Hawaiian/Pacific Islander, White	Title VI of the Civil Rights Act of 1964; 49 CFR Part 21; 23 CFR 200; 49 U.S.C. 5332(b); 49 U.S.C. 47123. <i>(Executive Order 13166)</i>

Color	Color of skin, including shade of skin within a racial group	Black, White, brown, yellow, etc.	
National Origin (<i>Limited English Proficiency</i>)	Place of birth. Citizenship is not a factor. (<i>Discrimination based on language or a person's accent is also covered</i>)	Mexican, Cuban, Japanese, Vietnamese, Chinese	
Sex	Gender. The sex of an individual. <i>Note: Sex under this program does not include sexual orientation.</i>	Women and Men	1973 Federal-Aid Highway Act; 49 U.S.C. 5332(b); 49 U.S.C. 47123.
Age	Persons of any age	21-year-old person	Age Discrimination Act of 1975 49 U.S.C. 5332(b); 49 U.S.C. 47123.
Disability	Physical or mental impairment, permanent or temporary, or perceived.	Blind, alcoholic, para-amputee, epileptic, diabetic, arthritic	Section 504 of the Rehabilitation Act of 1973; Americans with Disabilities Act of 1990
Religion (in the context of employment) (<i>Religion/ Creed in all aspects of any aviation or transit-related construction</i>)	An individual belonging to a religious group; or the perception, based on distinguishable characteristics that a person is a member of a religious group. In practice, actions taken as a result of the moral and ethical beliefs as to what is right and wrong, which are sincerely held with the strength of traditional religious views. <i>Note: Does not have to be associated with a recognized religious group or church; if an individual sincerely holds to the belief, it is a protected religious practice.</i>	Muslim, Christian, Sikh, Hindu, etc.	Title VII of the Civil Rights Act of 1964; 23 CFR 230; FHWA-1273 Required Contract Provisions. (<i>49 U.S.C. 5332(b); 49 U.S.C. 47123</i>)

(3) Pertinent Nondiscrimination Authorities

During the performance of this contract, the contractor, for itself, its assignees, and successors in interest agrees to comply with the following non-discrimination statutes and authorities, including, but not limited to:

- Title VI of the Civil Rights Act of 1964 (42 U.S.C. § 2000d et seq., 78 stat. 252), (prohibits discrimination on the basis of race, color, national origin); and 49 CFR Part 21.
- The Uniform Relocation Assistance and Real Property Acquisition Policies Act of 1970, (42 U.S.C. § 4601), (prohibits unfair treatment of persons displaced or whose property has been acquired because of Federal or Federal-aid programs and projects);
- Federal-Aid Highway Act of 1973, (23 U.S.C. § 324 et seq.), (prohibits discrimination on the basis of sex);
- Section 504 of the Rehabilitation Act of 1973, (29 U.S.C. § 794 et seq.), as amended, (prohibits discrimination on the basis of disability) and 49 CFR Part 27;
- The Age Discrimination Act of 1975, as amended, (42 U.S.C. § 6101 et seq.), (prohibits discrimination on the basis of age);

- Airport and Airway Improvement Act of 1982, (49 USC § 471, Section 47123), as amended, (prohibits discrimination based on race, creed, color, national origin, or sex);
- (g) The Civil Rights Restoration Act of 1987, (PL 100-209), (Broadened the scope, coverage and applicability of Title VI of the Civil Rights Act of 1964, The Age Discrimination Act of 1975 and Section 504 of the Rehabilitation Act of 1973, by expanding the definition of the terms "programs or activities" to include all of the programs or activities of the Federal-aid recipients, sub-recipients and contractors, whether such programs or activities are Federally funded or not);
- (h) Titles II and III of the Americans with Disabilities Act, which prohibit discrimination on the basis of disability in the operation of public entities, public and private transportation systems, places of public accommodation, and certain testing entities (42 U.S.C. §§ 12131-12189) as implemented by Department of Transportation regulations at 49 C.F.R. parts 37 and 38;
- (i) The Federal Aviation Administration's Nondiscrimination statute (49 U.S.C. § 47123) (prohibits discrimination on the basis of race, color, national origin, and sex);
- (j) Executive Order 12898, Federal Actions to Address Environmental Justice in Minority Populations and Low-Income Populations, which ensures Nondiscrimination against minority populations by discouraging programs, policies, and activities with disproportionately high and adverse human health or environmental effects on minority and low-income populations;
- (k) Executive Order 13166, Improving Access to Services for Persons with Limited English Proficiency, and resulting agency guidance, national origin discrimination includes discrimination because of Limited English proficiency (LEP). To ensure compliance with Title VI, you must take reasonable steps to ensure that LEP persons have meaningful access to your programs (70 Fed. Reg. at 74087 to 74100);
- (l) Title IX of the Education Amendments of 1972, as amended, which prohibits you from discriminating because of sex in education programs or activities (20 U.S.C. 1681 et seq).
- (m) Title VII of the Civil Rights Act of 1964 (42 U.S.C. § 2000e et seq., Pub. L. 88-352), (prohibits employment discrimination on the basis of race, color, religion, sex, or national origin).

(4) Additional Title VI Assurances

***The following Title VI Assurances (Appendices B, C and D) shall apply, as applicable*

(a) Clauses for Deeds Transferring United States Property (1050.2A, Appendix B)

The following clauses will be included in deeds effecting or recording the transfer of real property, structures, or improvements thereon, or granting interest therein from the United States pursuant to the provisions of Assurance 4.

NOW, THEREFORE, the U.S. Department of Transportation as authorized by law and upon the condition that the North Carolina Department of Transportation (NCDOT) will accept title to the lands and maintain the project constructed thereon in accordance with the North Carolina General Assembly, the Regulations for the Administration of the Federal-Aid Highway Program, and the policies and procedures prescribed by the Federal Highway Administration of the U.S. Department of Transportation in accordance and in compliance with all requirements imposed by Title 49, Code of Federal Regulations, U.S. Department of Transportation, Subtitle A, Office of the Secretary, Part 21, Nondiscrimination in Federally-assisted programs of the U.S. Department of Transportation pertaining to and effectuating the provisions of Title VI of the Civil Rights Act of 1964 (78 Stat. 252; 42 U.S.C. § 2000d to 2000d-4), does hereby remise, release, quitclaim and convey unto the NCDOT all the right, title and interest of the U.S. Department of Transportation in and to said lands described in Exhibit A attached hereto and made a part hereof.

(HABENDUM CLAUSE)

TO HAVE AND TO HOLD said lands and interests therein unto the North Carolina Department of Transportation (NCDOT) and its successors forever, subject, however, to the covenants, conditions, restrictions and reservations herein contained as follows, which will remain in effect for the period during which the real property or structures are used for a purpose for which Federal financial assistance is extended or for another purpose involving the provision of similar services or benefits and will be binding on the NCDOT, its successors and assigns.

The NCDOT, in consideration of the conveyance of said lands and interests in lands, does hereby covenant and agree as a covenant running with the land for itself, its successors and assigns, that (1) no person will on the grounds of race, color, or national origin, be excluded from participation in, be denied the benefits of, or be otherwise subjected to discrimination with regard to any facility located wholly or in part on, over, or under such lands hereby conveyed [,] [and]* (2) that the NCDOT will use the lands and interests in lands and interests in lands so conveyed, in compliance with all requirements imposed by or pursuant to Title 49, Code of Federal Regulations, U.S. Department of Transportation, Subtitle A, Office of the Secretary, Part 21, Nondiscrimination in Federally-assisted programs of the U.S. Department of Transportation, Effectuation of Title VI of the Civil Rights Act of 1964, and as said Regulations and Acts may be amended [, and (3) that in the event of breach of any of the above-mentioned nondiscrimination conditions, the Department will have a right to enter or re-enter said lands and facilities on said land, and that above described land and facilities will thereon revert to and vest in and become the absolute property of the U.S. Department of Transportation and its assigns as such interest existed prior to this instruction].*

(*Reverter clause and related language to be used only when it is determined that such a clause is necessary in order to make clear the purpose of Title VI.)

- (b) Clauses for Transfer of Real Property Acquired or Improved Under the Activity, Facility, or Program (1050.2A, Appendix C)

The following clauses will be included in deeds, licenses, leases, permits, or similar instruments entered into by the North Carolina Department of Transportation (NCDOT) pursuant to the provisions of Assurance 7(a):

1. The (grantee, lessee, permittee, etc. as appropriate) for himself/herself, his/her heirs, personal representatives, successors in interest, and assigns, as a part of the consideration hereof, does hereby covenant and agree [in the case of deeds and leases add "as a covenant running with the land"] that:
 - (i.) In the event facilities are constructed, maintained, or otherwise operated on the property described in this (deed, license, lease, permit, etc.) for a purpose for which a U.S. Department of Transportation activity, facility, or program is extended or for another purpose involving the provision of similar services or benefits, the (grantee, licensee, lessee, permittee, etc.) will maintain and operate such facilities and services in compliance with all requirements imposed by the Acts and Regulations (as may be amended) such that no person on the grounds of race, color, or national origin, will be excluded from participation in, denied the benefits of, or be otherwise subjected to discrimination in the use of said facilities.
2. With respect to licenses, leases, permits, etc., in the event of breach of any of the above Nondiscrimination covenants, the NCDOT will have the right to terminate the (lease, license, permit, etc.) and to enter, re-enter, and repossess said lands and facilities thereon, and hold the same as if the (lease, license, permit, etc.) had never been made or issued. *
3. With respect to a deed, in the event of breach of any of the above Nondiscrimination covenants, the NCDOT will have the right to enter or re-enter the lands and facilities thereon, and the above described lands and facilities will there upon revert to and vest in and become the absolute property of the NCDOT and its assigns. *

(*Reverter clause and related language to be used only when it is determined that such a clause is necessary to make clear the purpose of Title VI.)

- (c) Clauses for Construction/Use/Access to Real Property Acquired Under the Activity, Facility or Program (1050.2A, Appendix D)

The following clauses will be included in deeds, licenses, permits, or similar instruments/ agreements entered into by the North Carolina Department of Transportation (NCDOT) pursuant to the provisions of Assurance 7(b):

1. The (grantee, licensee, permittee, etc., as appropriate) for himself/herself, his/her heirs, personal representatives, successors in interest, and assigns, as a part of the consideration hereof, does hereby covenant and agree (in the case of deeds and leases add, "as a covenant running with the land") that (1) no person on the ground of race, color, or national origin, will be excluded from participation in, denied the benefits of, or be otherwise subjected to discrimination in the use of said facilities, (2) that in the construction of any improvements on, over, or under such land, and the furnishing of services thereon, no person on the ground of race, color, or national origin, will be excluded from participation in, denied the benefits of, or otherwise be subjected to discrimination, (3) that the (grantee, licensee, lessee, permittee, etc.) will use the premises in compliance with all other requirements imposed by or pursuant to the Acts and Regulations, as amended, set forth in this Assurance.
2. With respect to (licenses, leases, permits, etc.), in the event of breach of any of the above Non-discrimination covenants, the NCDOT will have the right to terminate the (license, permit, etc., as appropriate) and to enter or re-enter and repossess said land and the facilities thereon, and hold the same as if said (license, permit, etc., as appropriate) had never been made or issued. *
3. With respect to deeds, in the event of breach of any of the above Nondiscrimination covenants, the NCDOT will there upon revert to and vest in and become the absolute property of the NCDOT and its assigns. *

(*Reverter clause and related language to be used only when it is determined that such a clause is necessary to make clear the purpose of Title VI.)

STANDARD SPECIAL PROVISION**ON-THE-JOB TRAINING**

(10-16-07) (Rev. 4-21-15)

Z-10

Description

The North Carolina Department of Transportation will administer a custom version of the Federal On-the-Job Training (OJT) Program, commonly referred to as the Alternate OJT Program. All contractors (existing and newcomers) will be automatically placed in the Alternate Program. Standard OJT requirements typically associated with individual projects will no longer be applied at the project level. Instead, these requirements will be applicable on an annual basis for each contractor administered by the OJT Program Manager.

On the Job Training shall meet the requirements of 23 CFR 230.107 (b), 23 USC – Section 140, this provision and the On-the-Job Training Program Manual.

The Alternate OJT Program will allow a contractor to train employees on Federal, State and privately funded projects located in North Carolina. However, priority shall be given to training employees on NCDOT Federal-Aid funded projects.

Minorities and Women

Developing, training and upgrading of minorities and women toward journeyman level status is a primary objective of this special training provision. Accordingly, the Contractor shall make every effort to enroll minority and women as trainees to the extent that such persons are available within a reasonable area of recruitment. This training commitment is not intended, and shall not be used, to discriminate against any applicant for training, whether a member of a minority group or not.

Assigning Training Goals

The Department, through the OJT Program Manager, will assign training goals for a calendar year based on the contractors' past three years' activity and the contractors' anticipated upcoming year's activity with the Department. At the beginning of each year, all contractors eligible will be contacted by the Department to determine the number of trainees that will be assigned for the upcoming calendar year. At that time the Contractor shall enter into an agreement with the Department to provide a self-imposed on-the-job training program for the calendar year. This agreement will include a specific number of annual training goals agreed to by both parties. The number of training assignments may range from 1 to 15 per contractor per calendar year. The Contractor shall sign an agreement to fulfill their annual goal for the year.\

Training Classifications

The Contractor shall provide on-the-job training aimed at developing full journeyman level workers in the construction craft/operator positions. Preference shall be given to providing training in the following skilled work classifications:

Equipment Operators	Office Engineers
Truck Drivers	Estimators
Carpenters	Iron / Reinforcing Steel Workers
Concrete Finishers	Mechanics
Pipe Layers	Welders

The Department has established common training classifications and their respective training requirements that may be used by the contractors. However, the classifications established are not all-inclusive. Where the training is oriented toward construction applications, training will be allowed in lower-level management positions such as office engineers and estimators. Contractors shall submit new classifications for specific job functions that their employees are performing. The Department will review and recommend for acceptance to FHWA the new classifications proposed by contractors, if applicable. New classifications shall meet the following requirements:

Proposed training classifications are reasonable and realistic based on the job skill classification needs, and

The number of training hours specified in the training classification is consistent with common practices and provides enough time for the trainee to obtain journeyman level status.

The Contractor may allow trainees to be trained by a subcontractor provided that the Contractor retains primary responsibility for meeting the training and this provision is made applicable to the subcontract. However, only the Contractor will receive credit towards the annual goal for the trainee.

Where feasible, 25 percent of apprentices or trainees in each occupation shall be in their first year of apprenticeship or training. The number of trainees shall be distributed among the work classifications on the basis of the contractor's needs and the availability of journeymen in the various classifications within a reasonable area of recruitment.

No employee shall be employed as a trainee in any classification in which they have successfully completed a training course leading to journeyman level status or in which they have been employed as a journeyman.

Records and Reports

The Contractor shall maintain enrollment, monthly and completion reports documenting company compliance under these contract documents. These documents and any other information as requested shall be submitted to the OJT Program Manager.

Upon completion and graduation of the program, the Contractor shall provide each trainee with a certification Certificate showing the type and length of training satisfactorily completed.

Trainee Interviews

All trainees enrolled in the program will receive an initial and Trainee/Post graduate interview conducted by the OJT program staff.

Trainee Wages

Contractors shall compensate trainees on a graduating pay scale based upon a percentage of the prevailing minimum journeyman wages (Davis-Bacon Act). Minimum pay shall be as follows:

60 percent	of the journeyman wage for the first half of the training period
75 percent	of the journeyman wage for the third quarter of the training period
90 percent	of the journeyman wage for the last quarter of the training period

In no instance shall a trainee be paid less than the local minimum wage. The Contractor shall adhere to the minimum hourly wage rate that will satisfy both the NC Department of Labor (NCDOL) and the Department.

Achieving or Failing to Meet Training Goals

The Contractor will be credited for each trainee employed by him on the contract work who is currently enrolled or becomes enrolled in an approved program and who receives training for at least 50 percent of the specific program requirement. Trainees will be allowed to be transferred between projects if required by the Contractor's scheduled workload to meet training goals.

If a contractor fails to attain their training assignments for the calendar year, they may be taken off the NCDOT's Bidders List.

Measurement and Payment

No compensation will be made for providing required training in accordance with these contract documents.

AWARD LIMITS ON MULTIPLE PROJECTS

It is the desire of the Proposer to be awarded contracts, the value of which will not exceed a total of \$ _____, for those projects indicated below on which bids are being opened on the same date as shown in the Proposal Form. Individual projects shall be indicated by placing the project number and county in the appropriate place below. Projects not selected will not be subject to an award limit.

(Project Number)	(County)
(Project Number)	(County)
(Project Number)	(County)
(Project Number)	(County)

*If a Proposer desires to limit the total amount of work awarded to him in this letting, he shall state such limit in the space provided above in the second line of this form.

It is agreed that in the event that I am (we are) the successful bidder on indicated projects, the total value of which is more that the above stipulated award limits, the Board of Transportation will award me (us) projects from among those indicated which have a total value not exceeding the award limit and which will result in the best advantage to the Department of Transportation.

**Signature of Authorized Person

**Only those persons authorized to sign bids under the provisions of Article 102-8, Item 7, shall be authorized to sign this form.

ADDENDUM(S)

ADDENDUM #1

I, _____ representing _____
(SIGNATURE)

Acknowledge receipt of Addendum #1.

ADDENDUM #2

I, _____ representing _____
(SIGNATURE)

Acknowledge receipt of Addendum #2.

ADDENDUM #3

I, _____ representing _____
(SIGNATURE)

Acknowledge receipt of Addendum #3.

LISTING OF DBE SUBCONTRACTORS

Sheet of

Firm Name and Address	Item No.	Item Description	* Agreed upon Unit Price	** Dollar Volume of Item
Name Address				
Name Address				
Name Address				
Name Address				
Name Address				
Name Address				
Name Address				

* The Dollar Volume shown in this column shall be the Actual Price Agreed Upon by the Prime Contractor and the DBE subcontractor, and these prices will be used to determine the percentage of the DBE participation in the contract.

** Dollar Volume of DBE Subcontractor Percentage of Total Contract Bid Price:

If firm is a Material Supplier Only, show Dollar Volume as 60% of Agreed Upon Amount from Letter of Intent.

If firm is a Manufacturer, show Dollar Volume as 100% of Agreed Upon Amount from Letter of Intent.

LISTING OF DBE SUBCONTRACTORS

Sheet of

Firm Name and Address	Item No.	Item Description	* Agreed upon Unit Price	** Dollar Volume of Item
Name Address				
Name Address				
Name Address				
Name Address				
Name Address				

**** Dollar Volume of DBE Subcontractor \$ _____**

Percentage of Total Contract Bid Price _____%

*** The Dollar Volume shown in this column shall be the Actual Price Agreed Upon by the Prime Contractor and the DBE subcontractor, and these prices will be used to determine the percentage of the DBE participation in the contract.**

**** Dollar Volume of DBE Subcontractor Percentage of Total Contract Bid Price:
 If firm is a Material Supplier Only, show Dollar Volume as 60% of Agreed Upon Amount from Letter of Intent.
 If firm is a Manufacturer, show Dollar Volume as 100% of Agreed Upon Amount from Letter of Intent.**

**DEPARTMENT OF TRANSPORTATION
BID FORM**

WBS Element: 49218.16 & 49218.24

Project Description: Long Arm Mowing and Tree Removal on Fort Liberty.

LINE #	SECT #	DESCRIPTION	QUANTITY	UNIT	UNIT PRICE	AMOUNT BID
1	SP	Two(2) Fully Operated Long Arm Mowing Tractors and One (1) Shadow Truck with Traffic Control.	49.38	SMI		
2	SP	Tree Removal with Traffic Control.	247	EA		

<p><i>TOTAL BID FOR PROJECT:</i> _____</p>

CONTRACTOR _____

ADDRESS _____

Federal Identification Number _____ Contractor's License Number _____

Authorized Agent _____ Title _____

Signature _____ Date _____

Witness _____ Title _____

Signature _____ Date _____

EXECUTION OF BID

NON-COLLUSION, DEBARMENT AND GIFT BAN CERTIFICATION

CORPORATION

The prequalified bidder being duly sworn, solemnly swears (or affirms) that neither he, nor any official, agent or employee has entered into any agreement, participated in any collusion, or otherwise taken any action which is in restraint of free competitive bidding in connection with any bid or contract, that the prequalified bidder has not been convicted of violating N.C.G.S. §133-24 within the last three years, and that the prequalified bidder intends to do the work with his own bona fide employees or subcontractors and will not bid for the benefit of another contractor.

By submitting this non-collusion, debarment and gift ban certification, the Contractor is attesting his status under penalty of perjury under the laws of the United States in accordance with the Debarment Certification attached, provided that the Debarment Certification also includes any required statements concerning exceptions that are applicable.

N.C.G.S. §133-32 and Executive Order 24 prohibit the offer to, or acceptance by, any State Employee of any gift from anyone with a contract with the State, or from any person seeking to do business with the State. By execution of any response in this procurement, you attest, for your entire organization and its employees or agents, that you are not aware that any such gift has been offered, accepted, or promised by any employees of your organization.

SIGNATURE OF PREQUALIFIED BIDDER

Full name of Corporation

Address as Prequalified

Attest _____
Secretary/Assistant Secretary
(Select appropriate title)

By _____
President/Vice President/Assistant Vice President
(Select appropriate title)

Print or type Signer's name

Print or type Signer's name

CORPORATE SEAL

**NON-COLLUSION AFFIDAVIT, DEBARMENT CERTIFICATION AND GIFT BAN CERTIFICATION
PARTNERSHIP**

The prequalified bidder, being duly sworn, solemnly swears (or affirms) that neither he, nor any official, agent or employee has entered into any agreement, participated in any collusion, or otherwise taken any action which is in restraint of free competitive bidding in connection with any bid or contract, that the prequalified bidder has not been convicted of violating *N.C.G.S. § 133-24* within the last three years, and that the prequalified bidder intends to do the work with its own bona fide employees or subcontractors and will not bid for the benefit of another contractor.

By submitting this non-collusion, debarment and gift ban certification, the Contractor is attesting his status under penalty of perjury under the laws of the United States in accordance with the Debarment Certification attached, provided that the Debarment Certification also includes any required statements concerning exceptions that are applicable.

N.C.G.S. § 133-32 and Executive Order 24 prohibit the offer to, or acceptance by, any State Employee of any gift from anyone with a contract with the State, or from any person seeking to do business with the State. By execution of any response in this procurement, you attest, for your entire organization and its employees or agents, that you are not aware that any such gift has been offered, accepted, or promised by any employees of your organization.

SIGNATURE OF PREQUALIFIED BIDDER

Full Name of
Partnership

Address as
Prequalified

Signature of Witness

Signature of Partner

Print or Type Signer's Name

Print or Type Signer's Name

**NON-COLLUSION AFFIDAVIT, DEBARMENT CERTIFICATION AND GIFT BAN
CERTIFICATION**

LIMITED LIABILITY COMPANY

The prequalified bidder, being duly sworn, solemnly swears (or affirms) that neither he, nor any official, agent or employee has entered into any agreement, participated in any collusion, or otherwise taken any action which is in restraint of free competitive bidding in connection with any bid or contract, that the prequalified bidder has not been convicted of violating *N.C.G.S. § 133-24* within the last three years, and that the prequalified bidder intends to do the work with its own bona fide employees or subcontractors and will not bid for the benefit of another contractor.

By submitting this non-collusion, debarment and gift ban certification, the Contractor is attesting his status under penalty of perjury under the laws of the United States in accordance with the Debarment Certification attached, provided that the Debarment Certification also includes any required statements concerning exceptions that are applicable.

N.C.G.S. § 133-32 and Executive Order 24 prohibit the offer to, or acceptance by, any State Employee of any gift from anyone with a contract with the State, or from any person seeking to do business with the State. By execution of any response in this procurement, you attest, for your entire organization and its employees or agents, that you are not aware that any such gift has been offered, accepted, or promised by any employees of your organization.

SIGNATURE OF PREQUALIFIED BIDDER

Full Name of Firm

Address as Prequalified

Signature of Witness

Signature of Member/Manager/Authorized Agent
(Select appropriate Title)

Print or Type Signer's Name

Print or Type Signer's Name

NON-COLLUSION, DEBARMENT AND GIFT BAN CERTIFICATION

JOINT VENTURE (2) or (3)

The prequalified bidder, being duly sworn, solemnly swears (or affirms) that neither he, nor any official, agent or employee has entered into any agreement, participated in any collusion, or otherwise taken any action which is in restraint of free competitive bidding in connection with any bid or contract, that the prequalified bidder has not been convicted of violating *N.C.G.S. § 133-24* within the last three years, and that the prequalified bidder intends to do the work with its own bona fide employees or subcontractors and will not bid for the benefit of another contractor.

By submitting this non-collusion, debarment and gift ban certification, the Contractor is attesting his status under penalty of perjury under the laws of the United States in accordance with the Debarment Certification attached, provided that the Debarment Certification also includes any required statements concerning exceptions that are applicable.

N.C.G.S. § 133-32 and Executive Order 24 prohibit the offer to, or acceptance by, any State Employee of any gift from anyone with a contract with the State, or from any person seeking to do business with the State. By execution of any response in this procurement, you attest, for your entire organization and its employees or agents, that you are not aware that any such gift has been offered, accepted, or promised by any employees of your organization.

SIGNATURE OF PREQUALIFIED BIDDER

Instructions: **2 Joint Venturers** Fill in lines (1), (2) and (3) and execute. **3 Joint Venturers** Fill in lines (1), (2), (3) and (4) and execute. On Line (1), fill in the name of the Joint Venture Company. On Line (2), fill in the name of one of the joint venturers and execute below in the appropriate manner. On Line (3), print or type the name of the other joint venturer and execute below in the appropriate manner. On Line (4), fill in the name of the third joint venturer, if applicable and execute below in the appropriate manner.

(1) _____
Name of Joint Venture

(2) _____
Name of Contractor

Address as Prequalified

Signature of Witness or Attest

BY

Signature of Contractor

Print or Type Signer's Name

AND

Print or Type Signer's Name

If Corporation, affix Corporate Seal

(3) _____
Name of Contractor

Address as Prequalified

Signature of Witness or Attest

BY

Signature of Contractor

Print or Type Signer's Name

AND

Print or Type Signer's Name

If Corporation, affix Corporate Seal

(4) _____
Name of Contractor

Address as Prequalified

Signature of Witness or Attest

BY

Signature of Contractor

Print or Type Signer's Name

AND

Print or Type Signer's Name

If Corporation, affix Corporate Seal

**NON-COLLUSION AFFIDAVIT, DEBARMENT CERTIFICATION AND GIFT BAN
CERTIFICATION**

INDIVIDUAL DOING BUSINESS UNDER A FIRM NAME

The prequalified bidder, being duly sworn, solemnly swears (or affirms) that neither he, nor any official, agent or employee has entered into any agreement, participated in any collusion, or otherwise taken any action which is in restraint of free competitive bidding in connection with any bid or contract, that the prequalified bidder has not been convicted of violating *N.C.G.S. § 133-24* within the last three years, and that the prequalified bidder intends to do the work with its own bona fide employees or subcontractors and will not bid for the benefit of another contractor.

By submitting this non-collusion, debarment and gift ban certification, the Contractor is attesting his status under penalty of perjury under the laws of the United States in accordance with the Debarment Certification attached, provided that the Debarment Certification also includes any required statements concerning exceptions that are applicable.

N.C.G.S. § 133-32 and Executive Order 24 prohibit the offer to, or acceptance by, any State Employee of any gift from anyone with a contract with the State, or from any person seeking to do business with the State. By execution of any response in this procurement, you attest, for your entire organization and its employees or agents, that you are not aware that any such gift has been offered, accepted, or promised by any employees of your organization.

SIGNATURE OF PREQUALIFIED BIDDER

Name of Prequalified Bidder

Individual Name

Trading and Doing Business As

Full name of Firm

Address as Prequalified

Signature of Witness

Signature of Prequalified Bidder, Individual

Print or Type Signer's Name

Print or Type Signer's Name

NON-COLLUSION AFFIDAVIT, DEBARMENT CERTIFICATION AND GIFT BAN CERTIFICATION

INDIVIDUAL DOING BUSINESS IN HIS OWN NAME

The prequalified bidder, being duly sworn, solemnly swears (or affirms) that neither he, nor any official, agent or employee has entered into any agreement, participated in any collusion, or otherwise taken any action which is in restraint of free competitive bidding in connection with any bid or contract, that the prequalified bidder has not been convicted of violating *N.C.G.S. § 133-24* within the last three years, and that the prequalified bidder intends to do the work with its own bona fide employees or subcontractors and will not bid for the benefit of another contractor.

By submitting this non-collusion, debarment and gift ban certification, the Contractor is attesting his status under penalty of perjury under the laws of the United States in accordance with the Debarment Certification attached, provided that the Debarment Certification also includes any required statements concerning exceptions that are applicable.

N.C.G.S. § 133-32 and Executive Order 24 prohibit the offer to, or acceptance by, any State Employee of any gift from anyone with a contract with the State, or from any person seeking to do business with the State. By execution of any response in this procurement, you attest, for your entire organization and its employees or agents, that you are not aware that any such gift has been offered, accepted, or promised by any employees of your organization.

SIGNATURE OF PREQUALIFIED BIDDER

Name of Prequalified Bidder

Print or Type Name

Address as Prequalified

Signature of Prequalified Bidder, Individually

Print or type Signer's Name

Signature of Witness

Print or type Signer's name

DEBARMENT CERTIFICATION OF PREQUALIFIED BIDDER

Conditions for certification:

1. The prequalified bidder shall provide immediate written notice to the Department if at any time the bidder learns that his certification was erroneous when he submitted his debarment certification or explanation that is file with the Department, or has become erroneous because of changed circumstances.
2. The terms *covered transaction, debarred, suspended, ineligible, lower tier covered transaction, participant, person, primary covered transaction, principal, proposal, and voluntarily excluded*, as used in this provision, have the meanings set out in the Definitions and Coverage sections of the rules implementing Executive Order 12549. A copy of the Federal Rules requiring this certification and detailing the definitions and coverages may be obtained from the Contract Officer of the Department.
3. The prequalified bidder agrees by submitting this form, that he will not knowingly enter into any lower tier covered transaction with a person who is debarred, suspended, declared ineligible, or voluntarily excluded from participation in NCDOT contracts, unless authorized by the Department.
4. For Federal Aid projects, the prequalified bidder further agrees that by submitting this form he will include the Federal-Aid Provision titled *Required Contract Provisions Federal-Aid Construction Contract (Form FHWA PR 1273)* provided by the Department, without subsequent modification, in all lower tier covered transactions.
5. The prequalified bidder may rely upon a certification of a participant in a lower tier covered transaction that he is not debarred, suspended, ineligible, or voluntarily excluded from the covered transaction, unless he knows that the certification is erroneous. The bidder may decide the method and frequency by which he will determine the eligibility of his subcontractors.
6. Nothing contained in the foregoing shall be construed to require establishment of a system of records in order to render in good faith the certification required by this provision. The knowledge and information of a participant is not required to exceed that which is normally possessed by a prudent person in the ordinary course of business dealings.
7. Except as authorized in paragraph 6 herein, the Department may terminate any contract if the bidder knowingly enters into a lower tier covered transaction with a person who is suspended, debarred, ineligible, or voluntarily excluded from participation in this transaction, in addition to other remedies available by the Federal Government.

DEBARMENT CERTIFICATION

The prequalified bidder certifies to the best of his knowledge and belief, that he and his principals:

- a. Are not presently debarred, suspended, proposed for debarment, declared ineligible, or voluntarily excluded from covered transactions by any Federal department or agency;
- b. Have not within a three-year period preceding this proposal been convicted of or had a civil judgment rendered against them for commission of fraud or a criminal offense in connection with obtaining, attempting to obtain, or performing a public (Federal, State or local) transaction or contract under a public transaction; violation of Federal or State antitrust statutes or commission of embezzlement, theft, forgery, bribery, falsification or destruction of records; making false statements; or receiving stolen property;
- c. Are not presently indicted for or otherwise criminally or civilly charged by a governmental entity (Federal, State or local) with commission of any of the offenses enumerated in paragraph b. of this certification; and
- d. Have not within a three-year period preceding this proposal had one or more public transactions (Federal, State or local) terminated for cause or default.
- e. Will submit a revised Debarment Certification immediately if his status changes and will show in his bid proposal an explanation for the change in status.

If the prequalified bidder cannot certify that he is not debarred, he shall provide an explanation with this submittal. An explanation will not necessarily result in denial of participation in a contract.

Failure to submit a non-collusion affidavit and debarment certification will result in the prequalified bidder's bid being considered non-responsive.

Check here if an explanation is attached to this certification.

Execution of Contract

Contract No: 12123882

County: HOKE

ACCEPTED BY THE DEPARTMENT

Proposals Engineer

Date